



indoor air quality and energy saving

TECHNICAL DATA



CRHE-V



VENTILATION UNIT WITH HEAT RECOVERY FOR COMMERCIAL AND INDUSTRIAL BUILDINGS



CRHE-V

Non-residential ventilator unit with dual flow and high yield heat recovery. **All sizes are available also in the version with ENTHALPY EXCHANGER**

PERFORMANCE

Equipped with counter current heat exchanger in aluminium (Eurovent certified) and electronic backward blade ventilators. The total bypass as standard allows favourable climatic conditions to be taken advantage of outside the building for free cooling (or free heating) in automatic mode.

STRUCTURE

CRHE-V is manufactured using a profiled extruded aluminium frame and 36 mm thick sandwich panels, insulated in polyurethane foam. The panels and inner parts are manufactured in magnesium zinc, material that ensures high strength against corrosion and oxidation. A panel with shutter opening eases access to the filters (ePM1 70% (F7) for the renewed air flow and ePM10 50% (G4) or ePM10 50% (M5) for the extraction air flow). CRHE-V is prepared for installation outdoors (with an optional, specific protective roof) and indoors; it is supplied with 100 mm high aluminium bases for installation on the floor. Available in 6 sizes, it can be equipped with air post-treatment systems (inside the unit) such as: hot/cold water battery, electrical heater or direct expansion battery. CRHE-V was designed to enable easy configuration of the connection to the air distribution/captation ducts. It is also possible and easy to install post-air treatment devices after sale. The pre-heater is inside, between the filter and the heat exchanger.

CONTROLLI

CRHE-V was supplied with an electric box and control system; it is available in a version equipped with EVO-PH control and a version equipped with EVOD-PH-IP control prepared for complete integration in home automation systems (Modbus protocol with Ethernet connection or, on request, with the addition of connection RS485). The new version of our control systems enables extremely easy and rapid passage from a control system to another, even after installation with the single replacement of the remote panel.

The EVO-PH control has a coloured, backlit touch screen interface with intuitive viewing of the working status of the machine. It enables precise adjustment of ventilator speed and has a weekly, time schedule for automatic management of the ventilators. It can be controlled by an external switch to activate the booster function, it can automatically adjust the air flow rate if connected to an air quality probe, it can manage any air post treatment accessories, it automatically manages the bypass and prevents heat exchanger freezing by managing the speed of the ventilators or, if installed, an electrical pre-heating resistor (optional accessory outside the machine); it signals to the user the need to replace the filters (the clogging status of the filters is monitored by a pair of different pressure switches, supplied as standard) or an anomaly, indicating the origin. With the addition of optional accessories (COP kit and CAV kit installed on the channel) you can manage the ventilation machine in constant pressure or constant flow rate mode.

The EVOD-PH-IP control has the same characteristics as the EVO-PH version with the addition of Modbus communication protocol which allows full control of the machine by the supervision software of the home automation system. The implemented webserver allows interaction with the machine, even with an internet browser of a device connected (even from remote) to the home automation system in which the machine is inserted.

ACCESSORIES

CRHE-V can be equipped with other accessories such as:

- . R.H. of probe, CO₂ or CO₂ / VOC
- . Operating kit pressure or constant flow
- . protection roof for outside instalalzione
- . grilles and damper

For a more complete view of the characteristics of the control panels, please read the specific manuals

CRHE-V (vertical) - SIDE VIEW

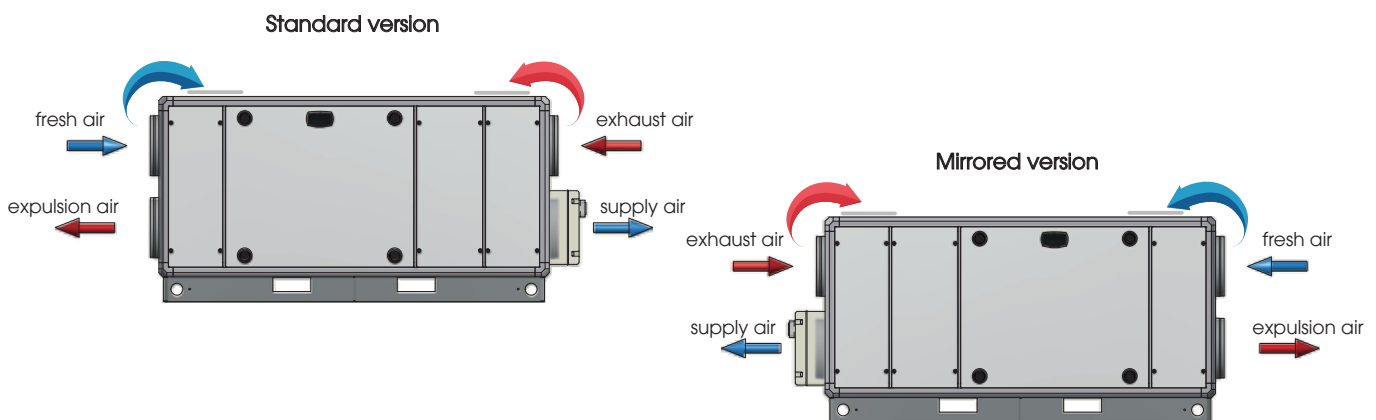

Counterflow heat exchanger made of aluminum manufactured by RECUTECH
RECUTECH participates in the Eurovent Certification Program

For the enthalpic version: counterflow heat exchanger manufactured by POLYBLOC
POLYBLOC participates in the Eurovent Certification Program



PERFORMANCE (UNI EN 13141-7)

The unit must be ducted properly: UTEK authorizes the use only according to its performance diagram shown into this catalogue
The declared performances are with CLEAN filters, and guaranteed ONLY with the original filters UTEK low pressure drop.

CRHE-V 700

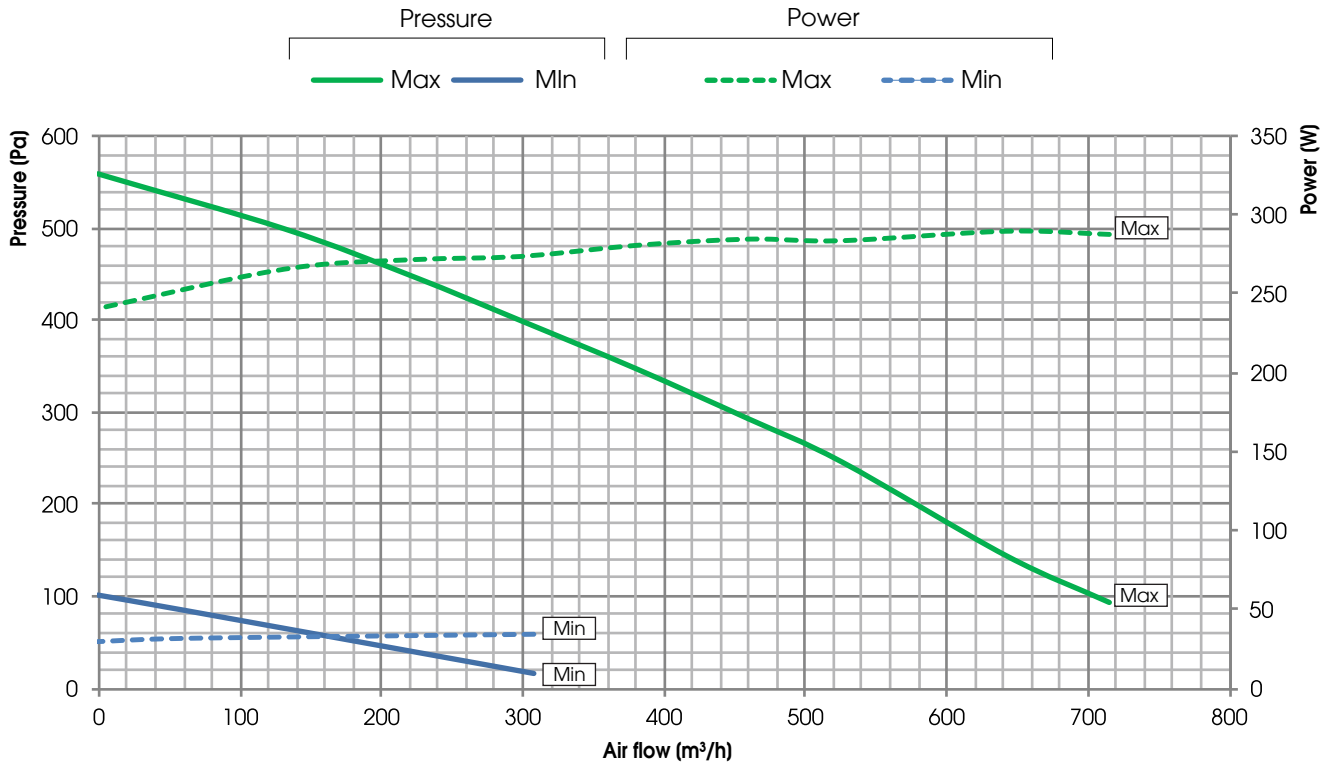

CRHE-V 1100

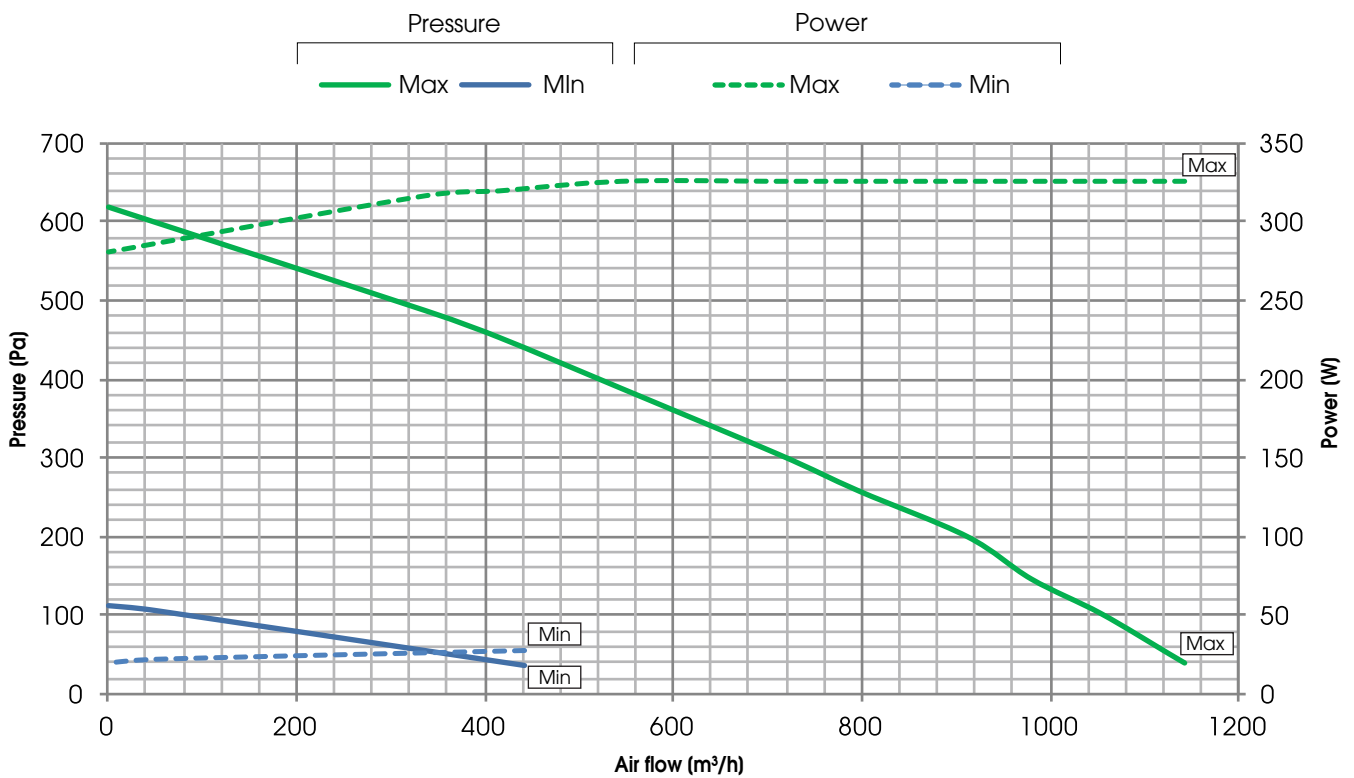



PERFORMANCE (UNI EN 13141-7)

The unit must be ducted properly; UTEK authorizes the use only according to its performance diagram shown into this catalogue
The declared performances are with CLEAN filters, and guaranteed ONLY with the original filters UTEK low pressure drop.

CRHE-V 1600

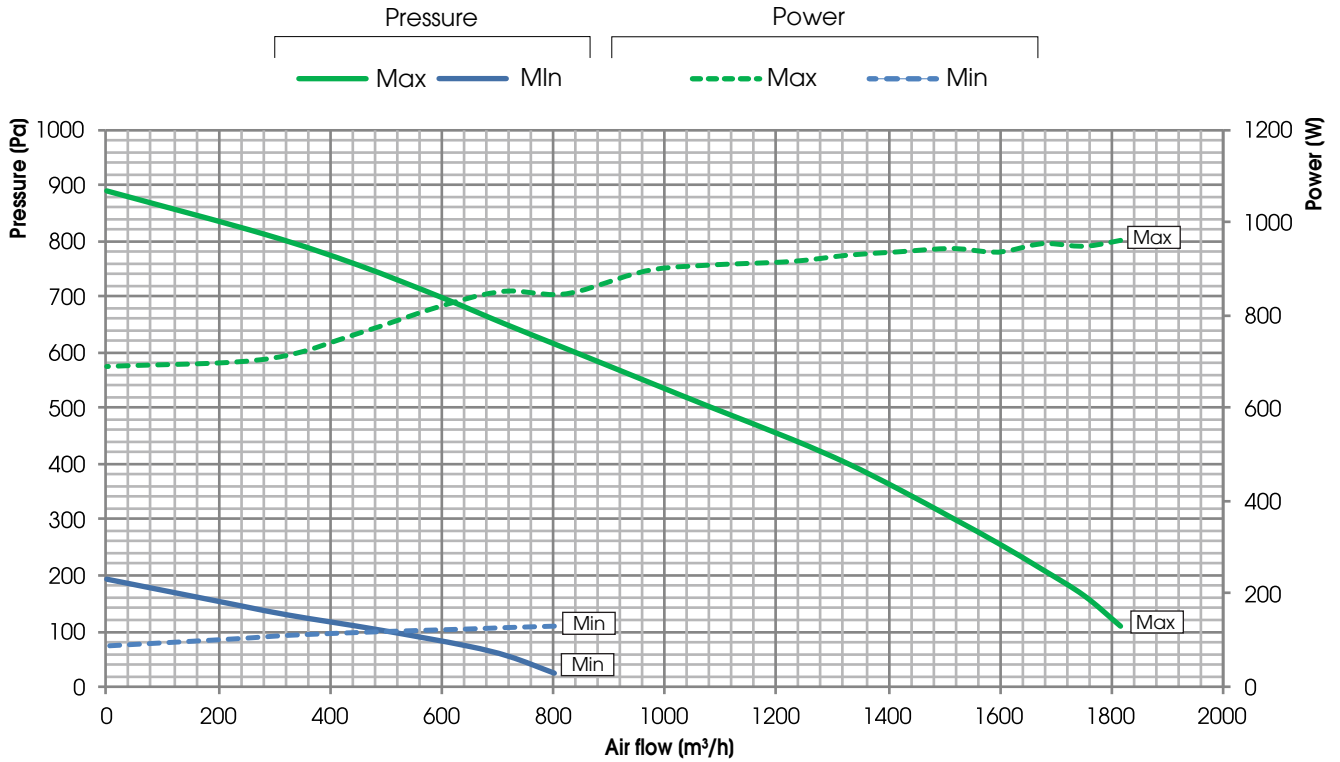

CRHE-V 2500

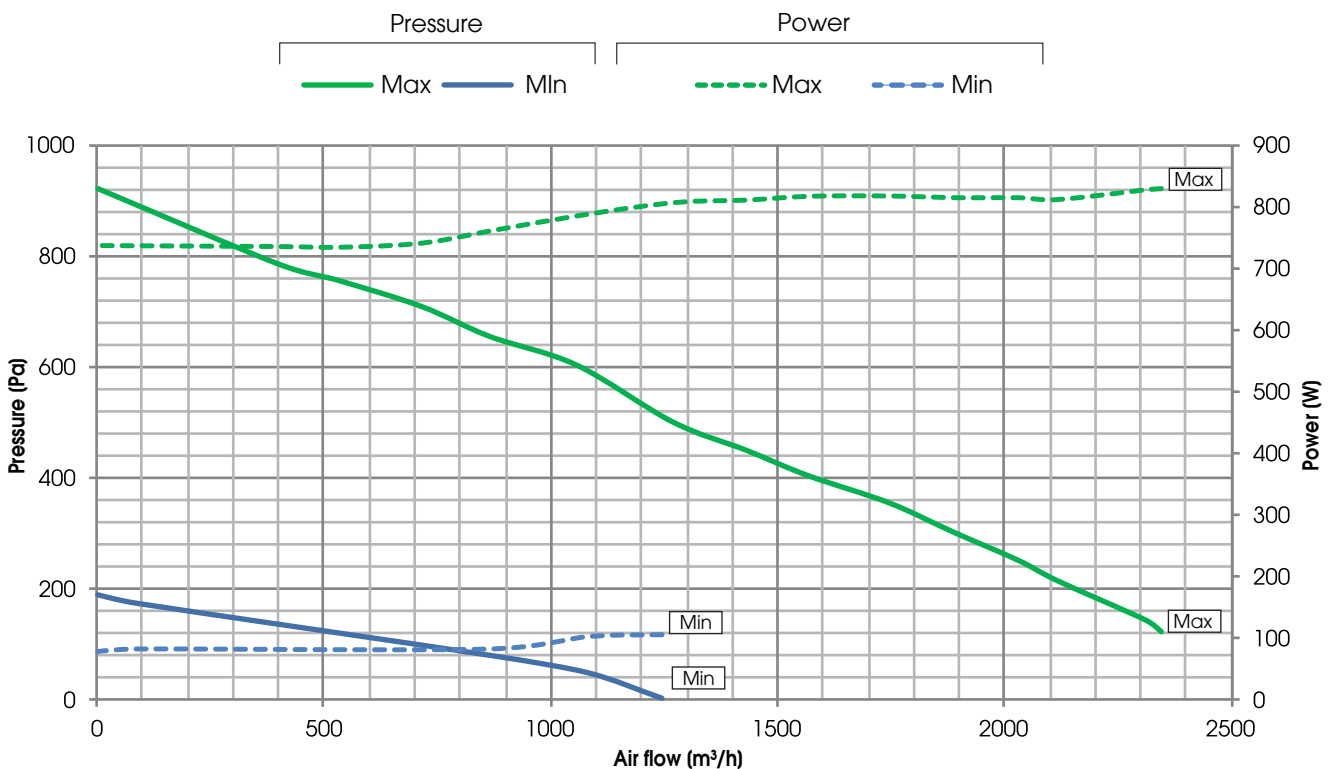



PERFORMANCE (UNI EN 13141-7)

The unit must be ducted properly: UTEK authorizes the use only according to its performance diagram shown into this catalogue
The declared performances are with CLEAN filters, and guaranteed ONLY with the original filters UTEK low pressure drop.

CRHE-V 3200

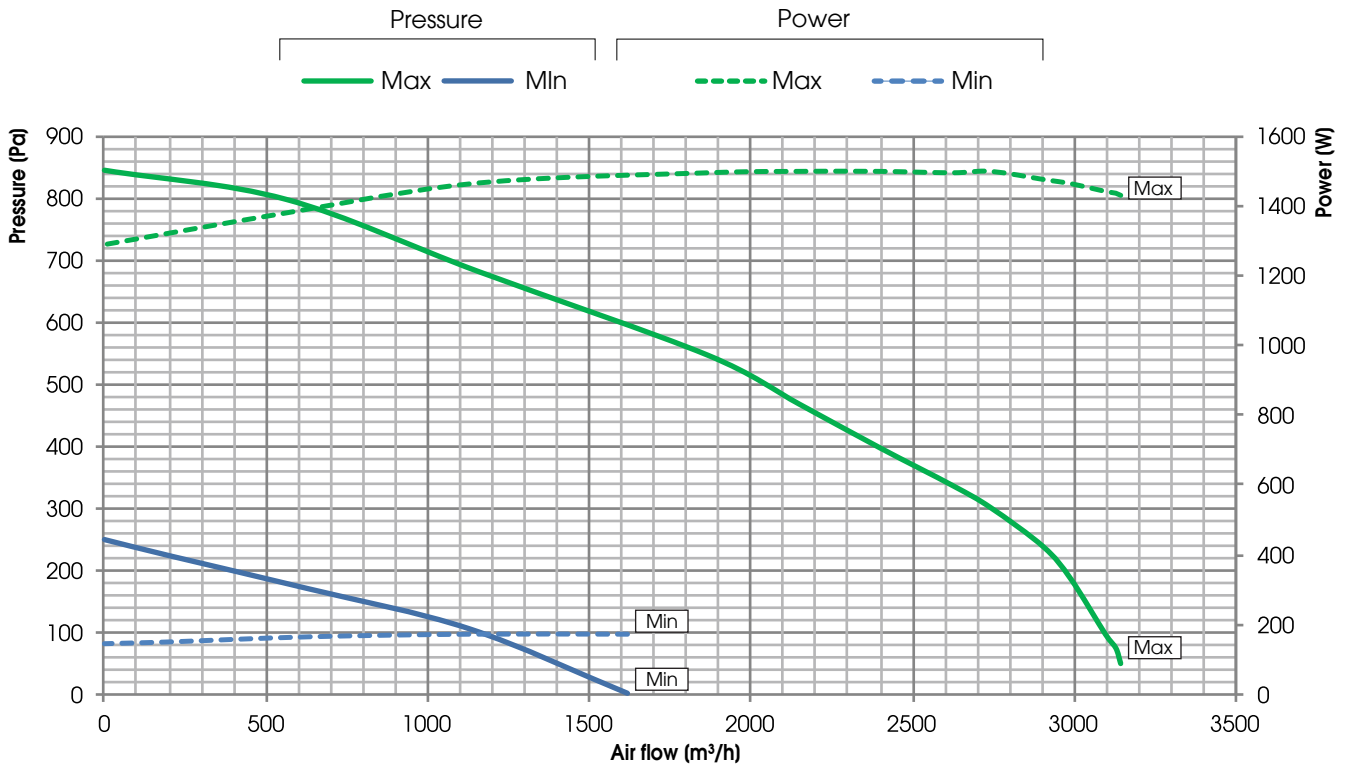

CRHE-V 4500

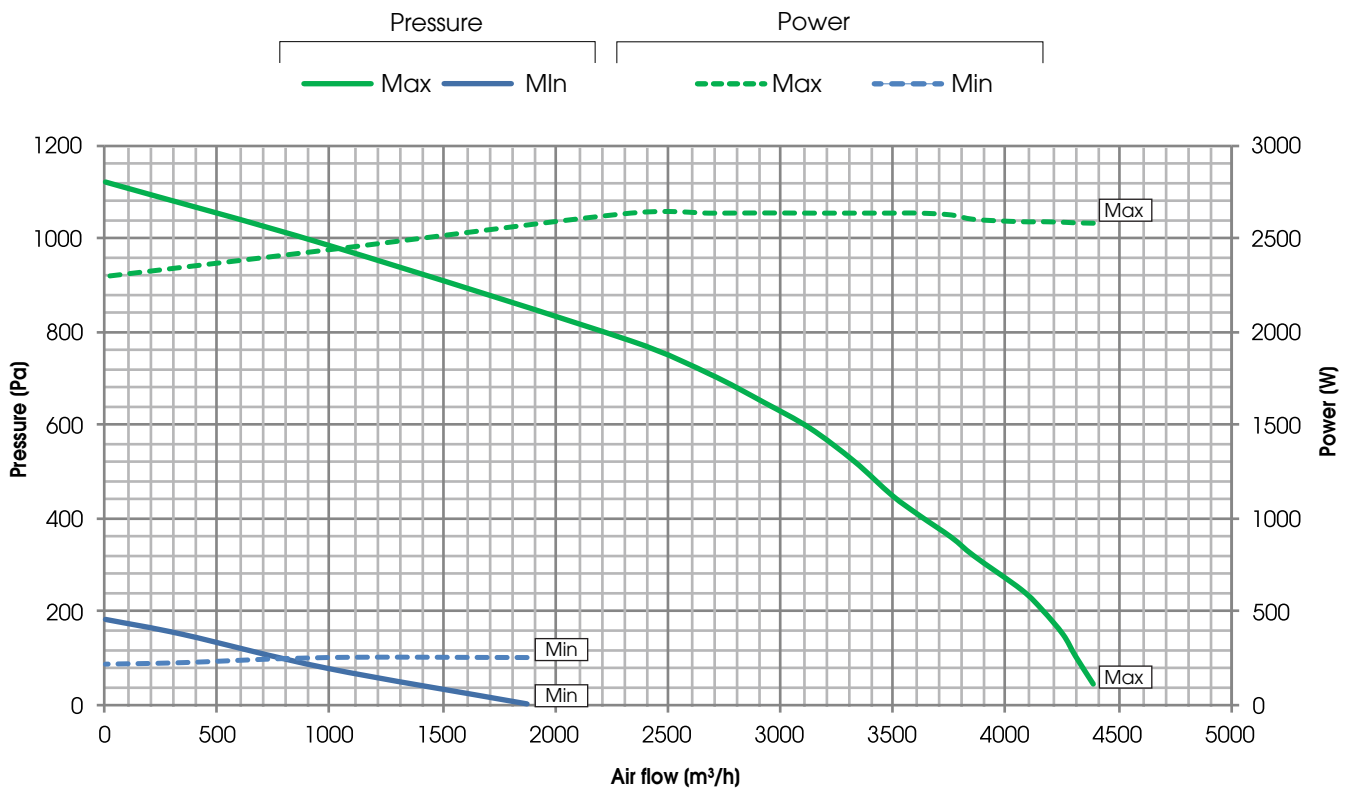



PERFORMANCE (UNI EN 13141-7)

The unit must be ducted properly: UTEK authorizes the use only according to its performance diagram shown into this catalogue
 The declared performances are with CLEAN filters, and guaranteed ONLY with the original filters UTEK low pressure drop.

CRHE-V 5600

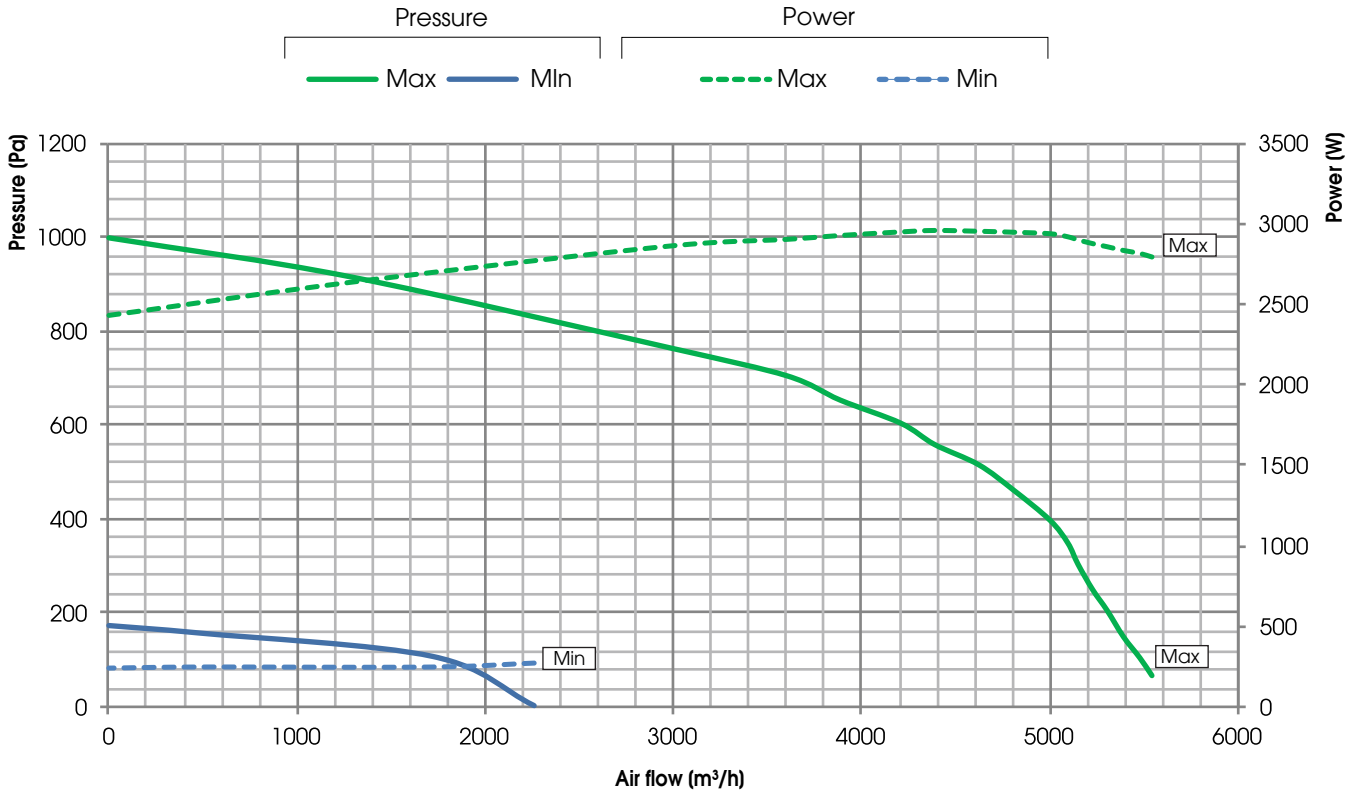

HEAT RECOVERY PERFORMANCE (sensible efficiency)

Values referred to the following conditions (UNI EN 308:1998): T_{bs} external air 5°C; U.R. external 72%; T_{bs} environment 25°C; U.R. environment 38%

- CRHE-V 700
- CRHE-V 1100
- CRHE-V 1600
- CRHE-V 2500
- CRHE-V 3200
- CRHE-V 4500
- CRHE-V 5600

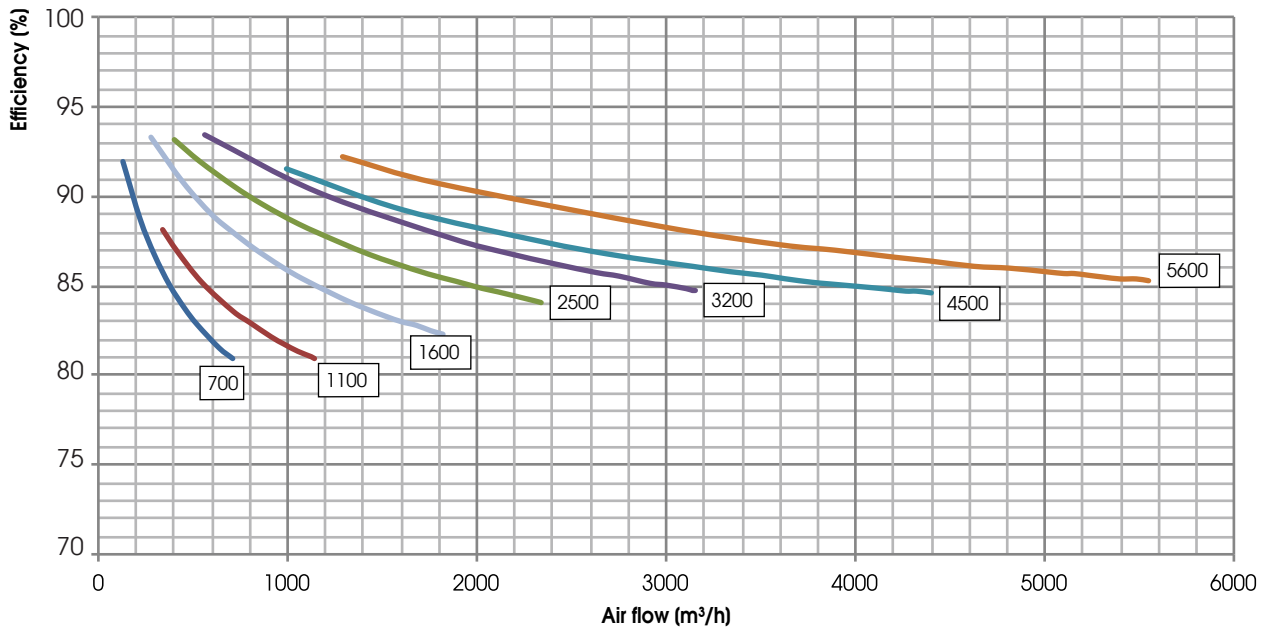



ECODESIGN

MOD.	$\eta_{t,nvru}$ (%)	q_{nom} (m ³ /s)	$\Delta p_{s,ext}$ (Pa)	P (kW)	SFP _{int} (W/(m ³ /s))	SFP _{int,lim 2016} (W/(m ³ /s))	SFP _{int,lim 2018} (W/(m ³ /s))	FRONTAL SPEED (m/s)	$\Delta p_{s,int}$ (Pa)	η_{Fan} (%)	* LEAKAGE internal (%)	* LEAKAGE external (%)
CRHE-V 700	82,2	0,16	200	0,29	843	1632	1352	1,21	475	56,5	9,5	5,4
CRHE-V 1100	82,2	0,25	200	0,33	460	1618	1338	1,31	278	58,5	7,1	4,6
CRHE-V 1600	82,7	0,47	200	0,95	1103	1601	1321	1,56	697	63,2	4,5	2,9
CRHE-V 2500	84,6	0,60	200	0,81	568	1639	1359	1,52	344	55,4	4,6	4,0
CRHE-V 3200	85,0	0,83	200	1,47	694	1617	1337	1,49	299	48,3	3,5	4,2
CRHE-V 4500	84,9	1,13	250	2,59	1040	1568	1288	2,00	480	51,4	2,8	3,6
CRHE-V 5600	85,6	1,45	250	2,88	782	1540	1260	1,80	370	54,0	2,3	3,0

* Compared to q_{nom}

VALUES ACCORDING UNI EN 1886: 2008

MOD.	CASING STRENGTH	CASING LEAKAGE	FILTER CLASS	THERMAL TRANSMITTANCE	THERMAL BRIDGE
CRHE-V 700	D1 (M)	L3 (M)	ePM1 70% (F7) (M)	T4 (M)	TB3 (M)
CRHE-V 1100	D1 (M)	L3 (M)	ePM1 70% (F7) (M)	T4 (M)	TB3 (M)
CRHE-V 1600	D1 (M)	L3 (M)	ePM1 70% (F7) (M)	T4 (M)	TB3 (M)
CRHE-V 2500	D1 (M)	L3 (M)	ePM1 70% (F7) (M)	T4 (M)	TB3 (M)
CRHE-V 3200	D1 (M)	L3 (M)	ePM1 70% (F7) (M)	T4 (M)	TB3 (M)
CRHE-V 4500	D1 (M)	L3 (M)	ePM1 70% (F7) (M)	T4 (M)	TB3 (M)
CRHE-V 5600	D1 (M)	L3 (M)	ePM1 70% (F7) (M)	T4 (M)	TB3 (M)

TEST LEAKAGE (UNI EN 13141-7)

LEAKAGE	TEST CONDITIONS	LEAKAGE CLASSIFICATION						
		CRHE-V 700	CRHE-V 1600	CRHE-V 1100	CRHE-V 2500	CRHE-V 3200	CRHE-V 4500	CRHE-V 5600
OUTDOOR	Positive pressure 400 Pa	A2	A2	A2	A2	A2	A2	A2
OUTDOOR	Negative pressure 400 Pa	A2	A2	A2	A2	A2	A1	A1
INDOOR	Pressure difference 250 Pa	A3	A2	A3	A2	A2	A2	A2

NOISE LEVEL

L_w Sound level taken in accordance to UNI EN ISO 3747
($\Delta L_f A \geq 7$ dB for each measurement position, class accuracy 2)

CRHE-V 700	NOISE FROM THE CASE (dB)							
	125 Hz	250 Hz	500 Hz	1000 Hz	2000 Hz	4000 Hz	8000 Hz	L _w dB(A)
	53	58	54	46	42	38	44	54,7
CRHE-V 700	NOISE IN THE DUCTS (dB)							
	125 Hz	250 Hz	500 Hz	1000 Hz	2000 Hz	4000 Hz	8000 Hz	L _w dB(A)
	63	62	60	56	54	54	62	65,0
CRHE-V 1100	NOISE FROM THE CASE (dB)							
	125 Hz	250 Hz	500 Hz	1000 Hz	2000 Hz	4000 Hz	8000 Hz	L _w dB(A)
	58	60	53	47	45	44	46	56,2
CRHE-V 1100	NOISE IN THE DUCTS (dB)							
	125 Hz	250 Hz	500 Hz	1000 Hz	2000 Hz	4000 Hz	8000 Hz	L _w dB(A)
	65	68	63	59	56	48	55	65,3
CRHE-V 1600	NOISE FROM THE CASE (dB)							
	125 Hz	250 Hz	500 Hz	1000 Hz	2000 Hz	4000 Hz	8000 Hz	L _w dB(A)
	69	67	61	54	51	43	46	62,9
CRHE-V 1600	NOISE IN THE DUCTS (dB)							
	125 Hz	250 Hz	500 Hz	1000 Hz	2000 Hz	4000 Hz	8000 Hz	L _w dB(A)
	72	70	68	66	64	63	67	72,6



CRHE-V 2500	NOISE FROM THE CASE (dB)							
	125 Hz	250 Hz	500 Hz	1000 Hz	2000 Hz	4000 Hz	8000 Hz	L _w dB(A)
	63	67	60	50	43	36	46	61,5
CRHE-V 2500	NOISE IN THE DUCTS (dB)							
	125 Hz	250 Hz	500 Hz	1000 Hz	2000 Hz	4000 Hz	8000 Hz	L _w dB(A)
	65	72	69	67	63	60	63	72,2
CRHE-V 3200	NOISE FROM THE CASE (dB)							
	125 Hz	250 Hz	500 Hz	1000 Hz	2000 Hz	4000 Hz	8000 Hz	L _w dB(A)
	67	71	66	58	49	44	48	66,4
CRHE-V 3200	NOISE IN THE DUCTS (dB)							
	125 Hz	250 Hz	500 Hz	1000 Hz	2000 Hz	4000 Hz	8000 Hz	L _w dB(A)
	66	76	72	71	67	65	70	76,2
CRHE-V 4500	NOISE FROM THE CASE (dB)							
	125 Hz	250 Hz	500 Hz	1000 Hz	2000 Hz	4000 Hz	8000 Hz	L _w dB(A)
	70	76	69	61	53	47	49	70,7
CRHE-V 4500	NOISE IN THE DUCTS (dB)							
	125 Hz	250 Hz	500 Hz	1000 Hz	2000 Hz	4000 Hz	8000 Hz	L _w dB(A)
	73	81	77	75	70	67	71	80,3
CRHE-V 5600	NOISE FROM THE CASE (dB)							
	125 Hz	250 Hz	500 Hz	1000 Hz	2000 Hz	4000 Hz	8000 Hz	L _w dB(A)
	73	78	73	66	57	51	55	73,9
CRHE-V 5600	NOISE IN THE DUCTS (dB)							
	125 Hz	250 Hz	500 Hz	1000 Hz	2000 Hz	4000 Hz	8000 Hz	L _w dB(A)
	75	88	77	75	69	66	70	82,2

ELECTRICAL DATA

MATCHING	FANS				UNIT CRHE-V		
	Power (W)	Supply	Current max.(A)	Insulation class	Supply	Current max.(A)	Insulation class
CRHE-V 700	2 x 145	230V 50/60 Hz 1F	2 x 1,20	IP54 CLASS B	230V 50 Hz 1F	2,5	IP 20
CRHE-V 1100	2 x 170	230V 50/60 Hz 1F	2 x 1,40	IP54 CLASS B	230V 50 Hz 1F	2,9	IP 20
CRHE-V 1600	2 x 448	230V 50/60 Hz 1F	2 x 2,80	IP54 CLASS B	230V 50 Hz 1F	5,7	IP 20
CRHE-V 2500	2 x 448	230V 50/60 Hz 1F	2 x 2,80	IP54 CLASS B	230V 50 Hz 1F	5,7	IP 20
CRHE-V 3200	2 x 715	230V 50/60 Hz 1F	2 x 3,10	IP54 CLASS B	230V 50 Hz 1F	6,3	IP 20
CRHE-V 4500	2 x 1270	230V 50/60 Hz 1F	2 x 5,60	IP54 CLASS B	230V 50 Hz 1F	11,3	IP 20
CRHE-V 5600	2 x 1400	230V 50/60 Hz 1F	2 x 6,00	IP54 CLASS B	230V 50 Hz 1F	12,1	IP 20

DIMENSIONS (mm) WEIGHT (kg)

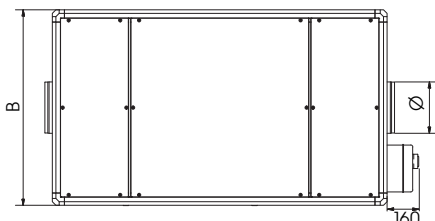
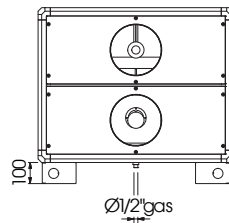
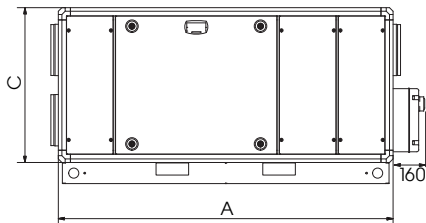

MODELL	Dimensions (mm)				
	A	B	C	Ø	Weight (kg)
CRHE-V 700	1475	760	660	200	104
CRHE-V 1100	1645	960	760	250	140
CRHE-V 1600	2000	970	980	355	222
CRHE-V 2500	2150	1060	1180	355	268
CRHE-V 3200	2305	1460	1180	450	352
CRHE-V 4500	2465	1360	1320	500	406
CRHE-V 5600	2545	1910	1320	560	674



INSTALLATION CRHE-V FLOOR INSTALLATION

Minimum required space for maintenance (mm)

MODELL	Dimensions (mm)			
	A	B	D	E
CRHE-V 700	760	985	420	240
CRHE-V 1100	860	1125	470	270
CRHE-V 1600	1080	1320	600	400
CRHE-V 2500	1280	1550	680	350
CRHE-V 3200	1280	1625	680	430
CRHE-V 4500	1420	1785	750	430
CRHE-V 5600	1420	1865	750	430

MODELL	Dimensions (mm)		
	C	E	F
CRHE-V 700	800	240	460
CRHE-V 1100	850	270	510
CRHE-V 1600	1000	430	630
CRHE-V 2500	950	350	720
CRHE-V 3200	1320	430	720
CRHE-V 4500	1320	430	790
CRHE-V 5600	1830	430	790

maintenance and replacement
of water coil or electric heater

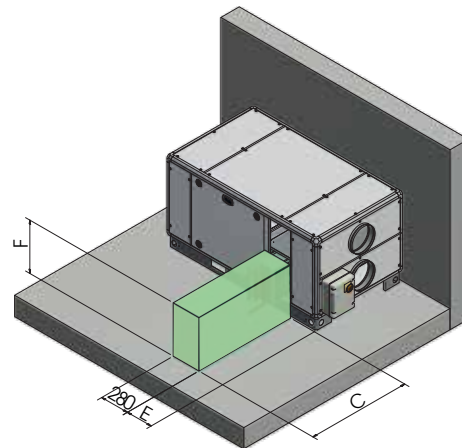
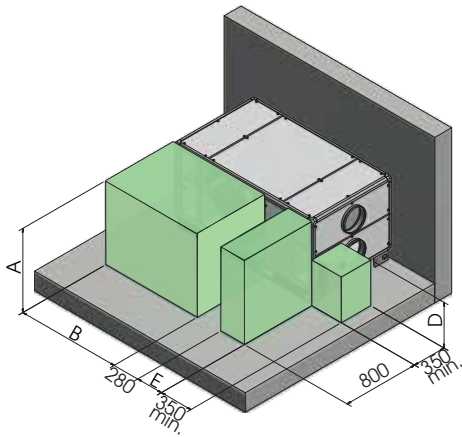

STANDARD SIPHON (mm)

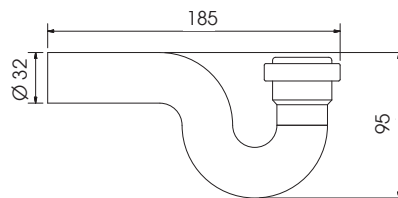

N.B.: provide for 1 additional siphon if the BA-AF / AC or DX gas cold-water coil is used



The way to read the graphs is specified within the accessories technolisto.

COILS CRHE-V 700 Cooling water coil (7°C/12°C)

Ø WATER (”gas)	N. ROWS	FIN PITCH (mm)	INT.VOL. (dm³)	MATERIALS		
				TUBES	FINS	FRAME
1/2”	4	2,5	2	Cu	Al	Fe Zn

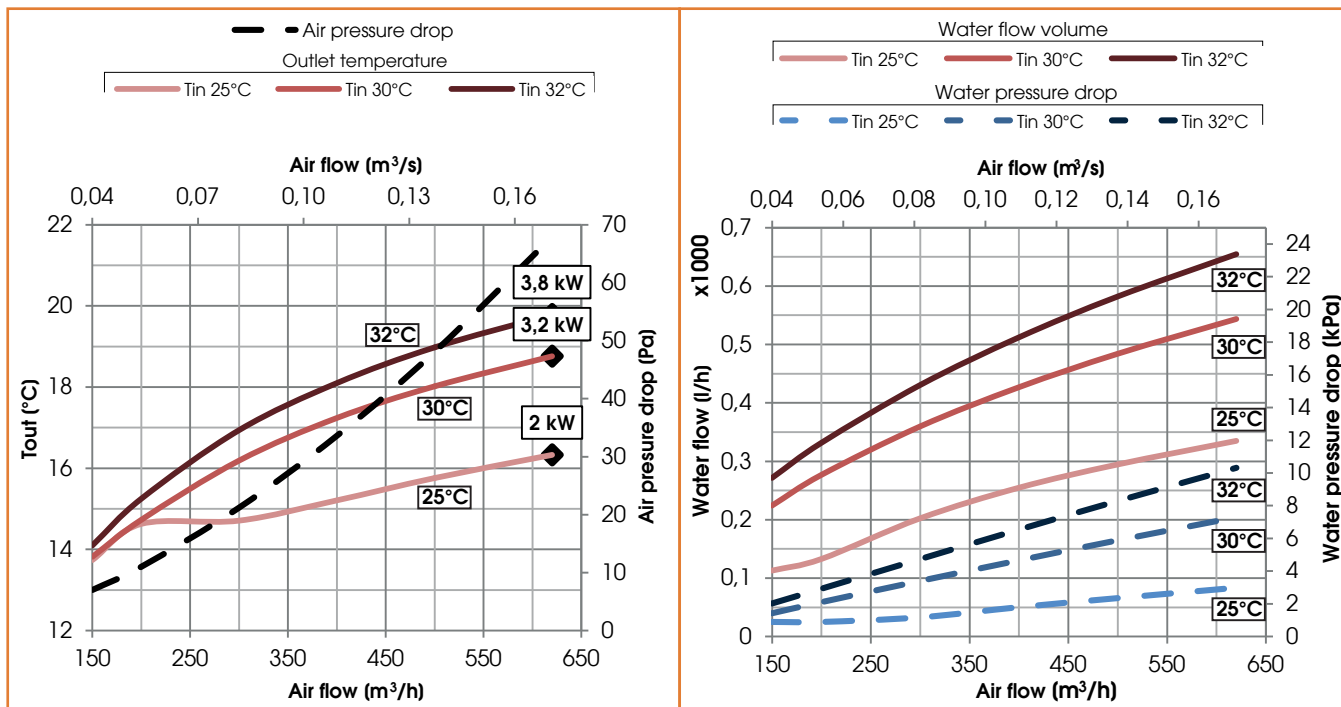

Heating water coil (45°C/35°C)

Ø WATER (”gas)	N. ROWS	FIN PITCH (mm)	INT.VOL. (dm³)	MATERIALS		
				TUBES	FINS	FRAME
1/2”	4	2,5	2	Cu	Al	Fe Zn

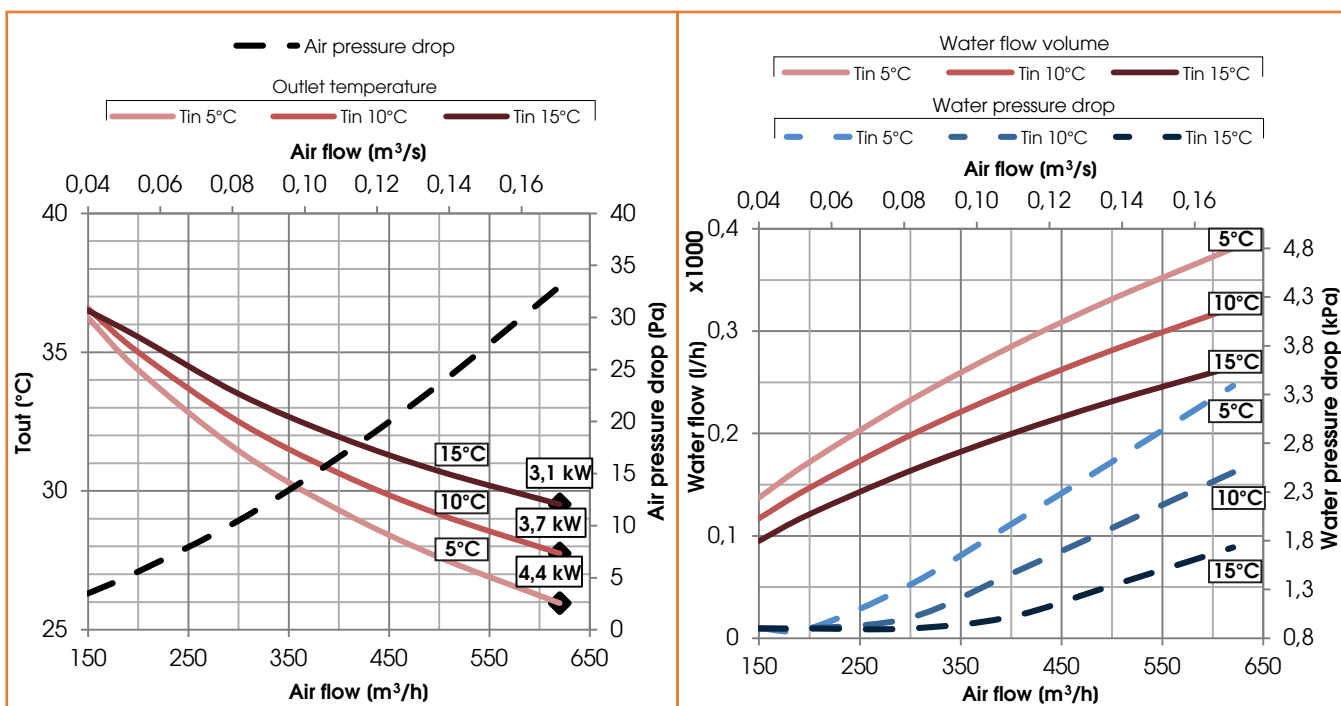



COILS CRHE-V 1100 Cooling water coil (7°C/12°C)

Ø WATER ("gas)	N. ROWS	FIN PITCH (mm)	INT.VOL. (dm³)	MATERIALS		
				TUBES	FINS	FRAME
3/4"	4	2,5	3	Cu	Al	Fe Zn

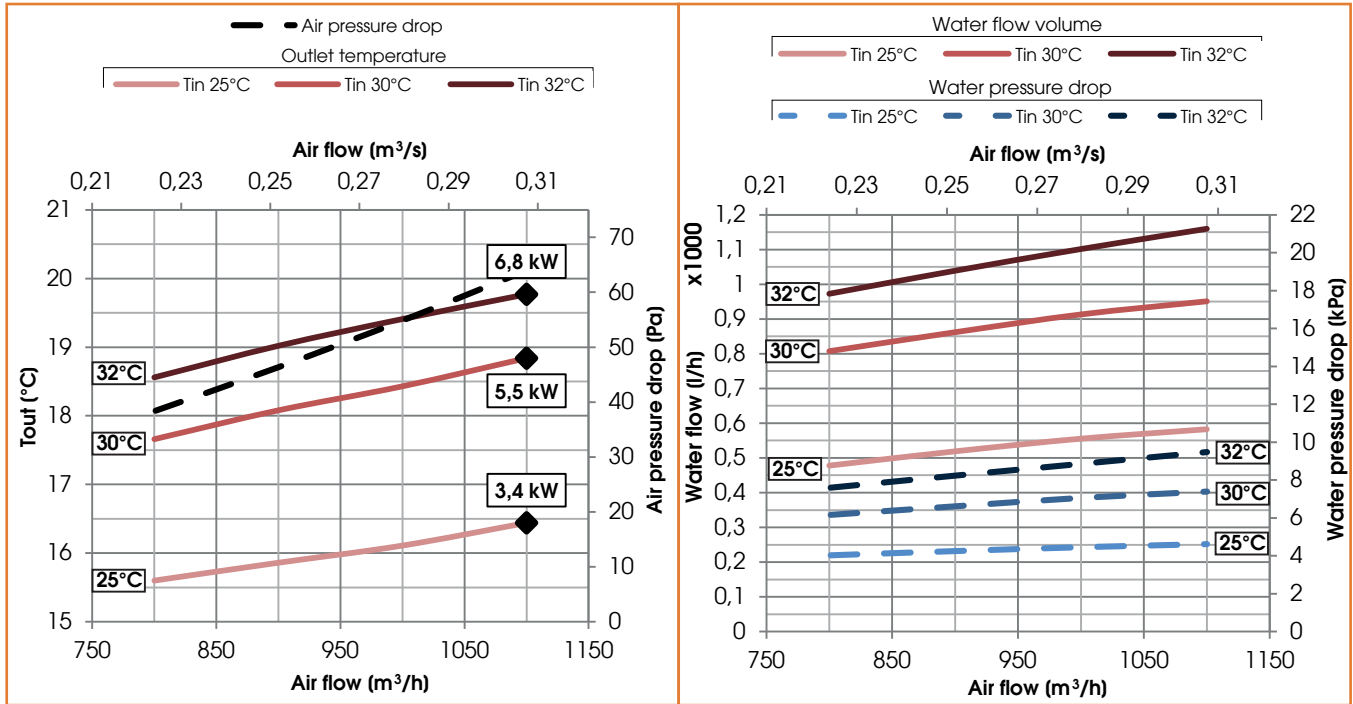

Heating water coil (45°C/35°C)

Ø WATER ("gas)	N. ROWS	FIN PITCH (mm)	INT.VOL. (dm³)	MATERIALS		
				TUBES	FINS	FRAME
3/4"	4	2,5	3	Cu	Al	Fe Zn

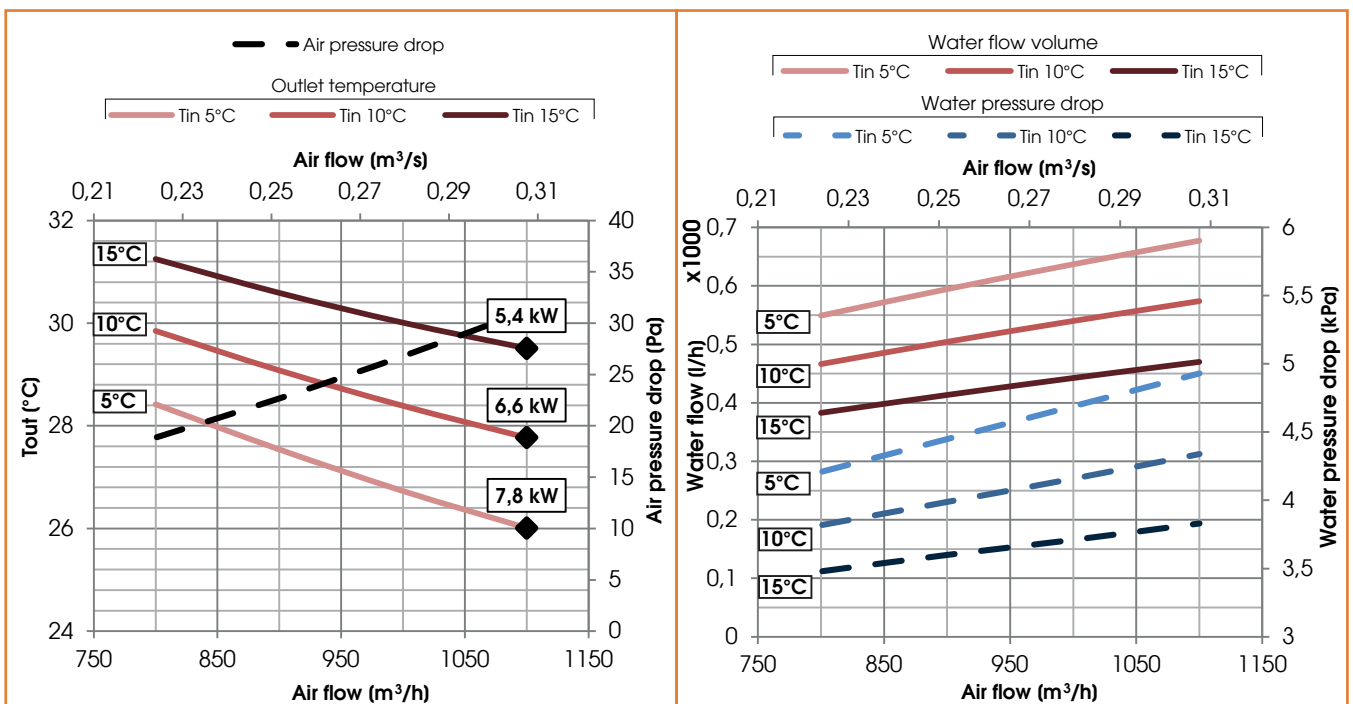



BATTERIE CRHE-V 1600
Cooling water coil (7°C/12°C)

Ø WATER ("gas)	N. ROWS	FIN PITCH (mm)	INT.VOL. (dm³)	MATERIAL		
				TUBES	FINS	FRAME
3/4"	4	2,5	5	Cu	Al	Fe Zn

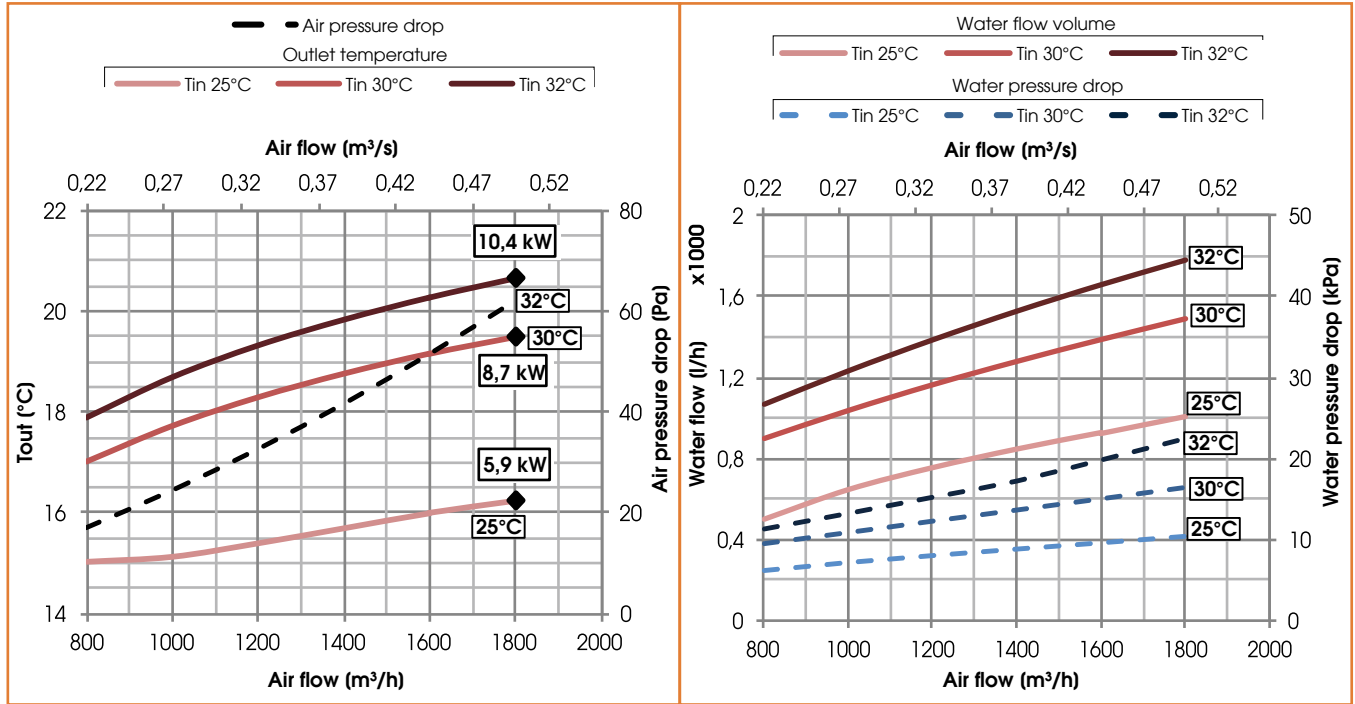

Heating water coil (45°C/35°C)

Ø WATER ("gas)	N. ROWS	FIN PITCH (mm)	INT.VOL. (dm³)	MATERIAL		
				TUBES	FINS	FRAME
3/4"	4	2,5	5	Cu	Al	Fe Zn

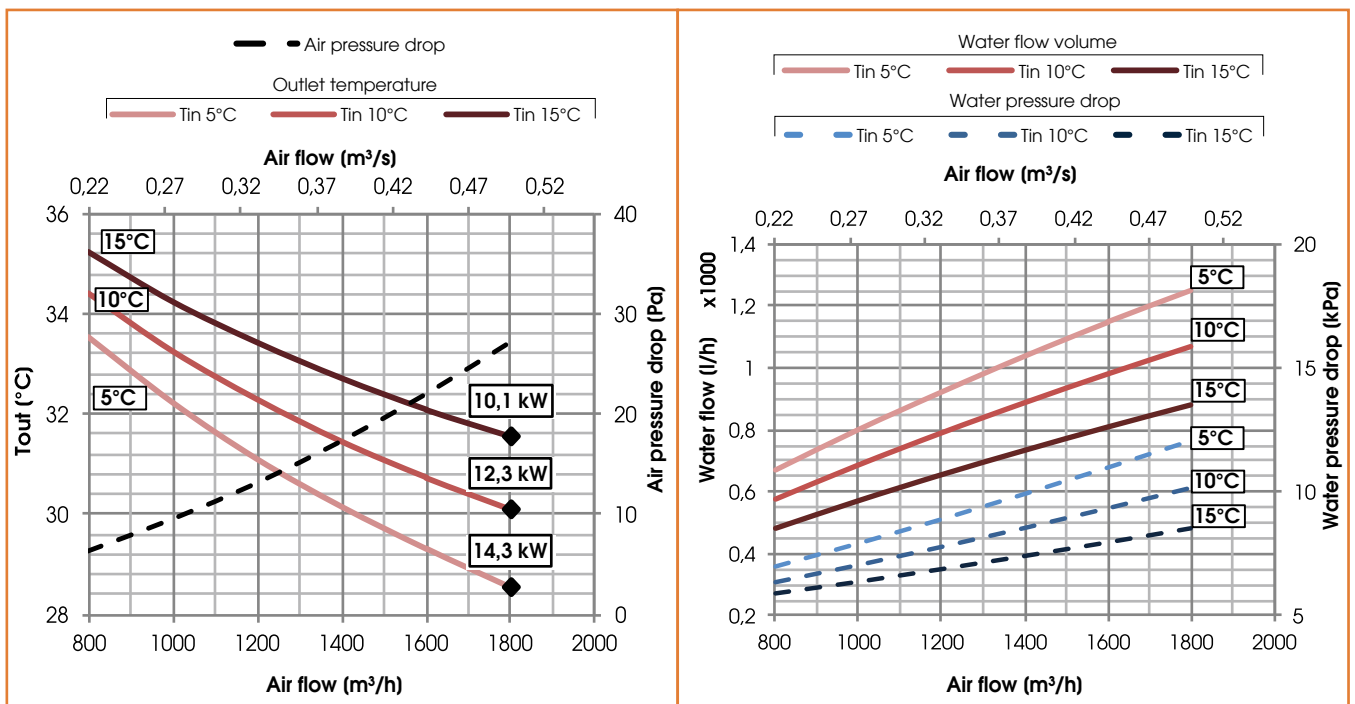



COILS CRHE-V 2500
Cooling water coil (7°C/12°C)

Ø WATER ("gas)	N. ROWS	FIN PITCH (mm)	INT.VOL. (dm³)	MATERIALS		
				TUBES	FINS	FRAME
3/4"	4	2,5	6	Cu	Al	Fe Zn

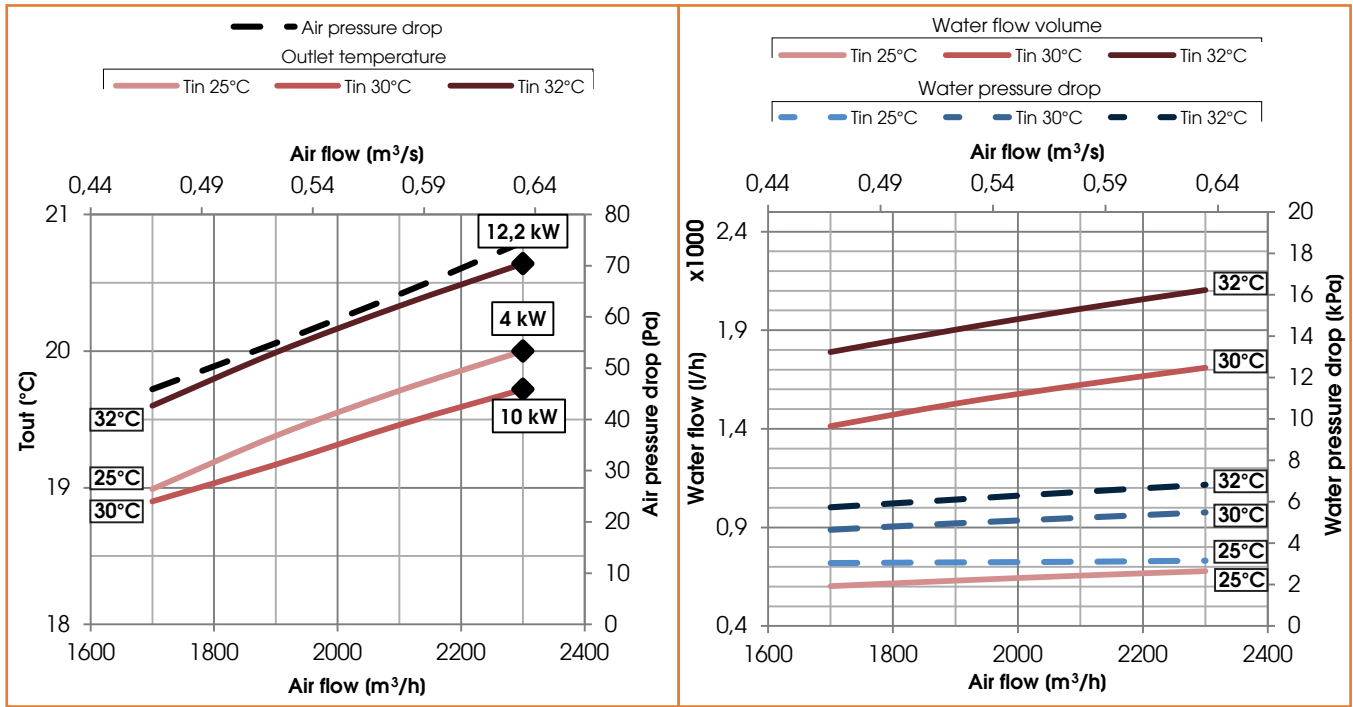

Heating water coil (45°C/35°C)

Ø WATER ("gas)	N. ROWS	FIN PITCH (mm)	INT.VOL. (dm³)	MATERIALS		
				TUBES	FINS	FRAME
3/4"	4	2,5	6	Cu	Al	Fe Zn

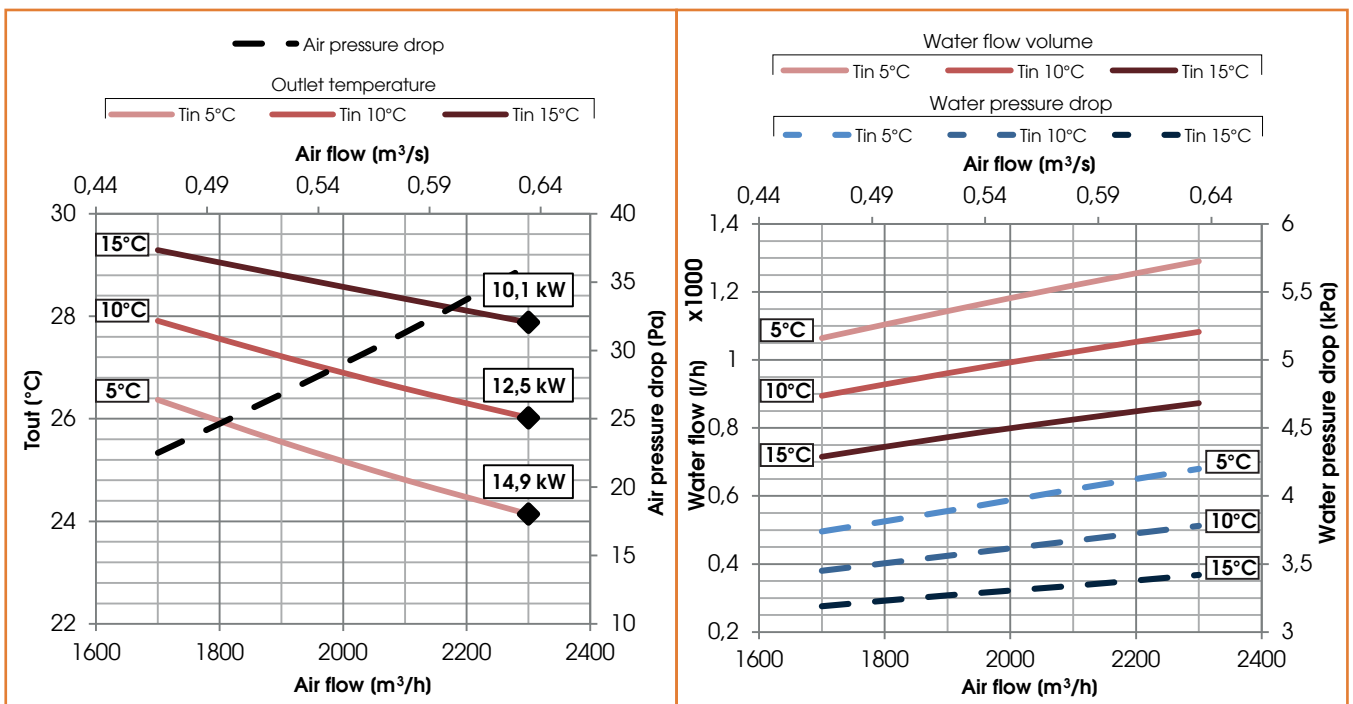



COILS CRHE-V 3200
Cooling water coil (7°C/12°C)

Ø WATER (”gas)	N. ROWS	FIN PITCH (mm)	INT.VOL. (dm³)	MATERIALS		
				TUBES	FINS	FRAME
1”	3	2,5	7	Cu	Al	Fe Zn

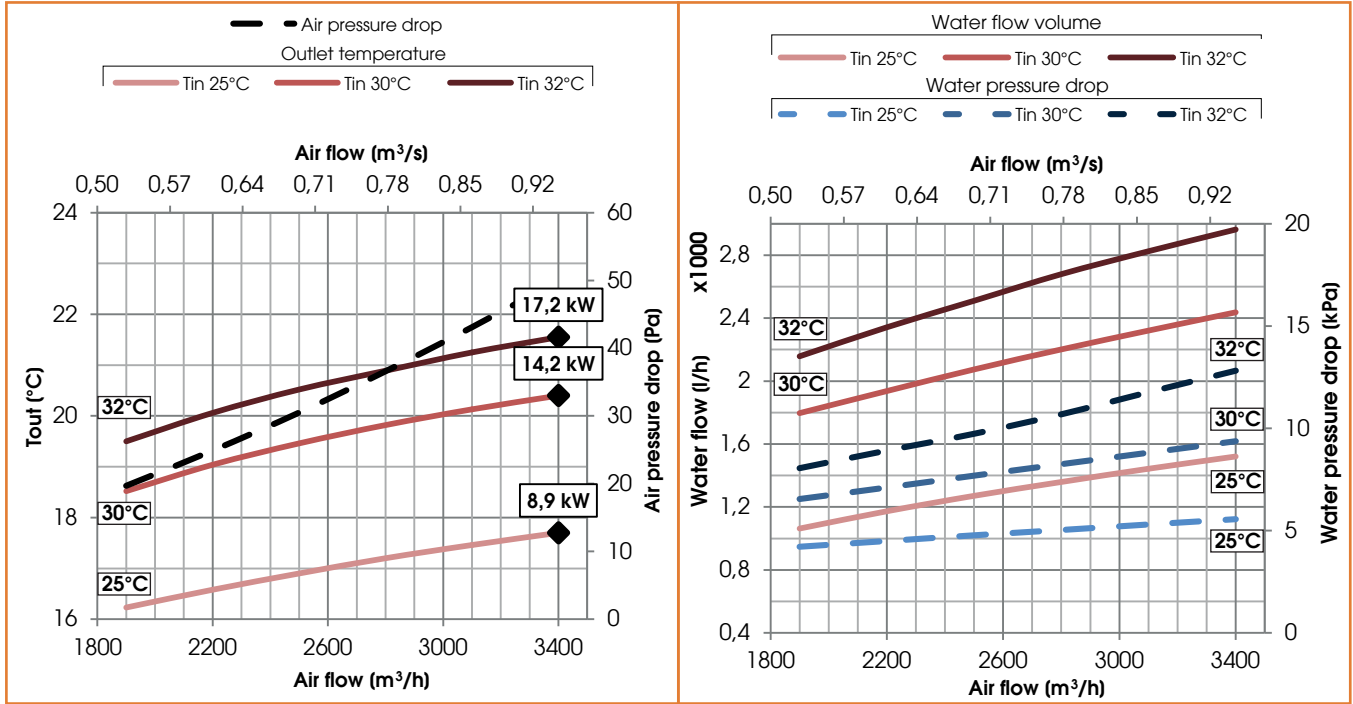

Heating water coil (45°C/35°C)

Ø WATER (”gas)	N. ROWS	FIN PITCH (mm)	INT.VOL. (dm³)	MATERIALS		
				TUBES	FINS	FRAME
1”	3	2,5	7	Cu	Al	Fe Zn

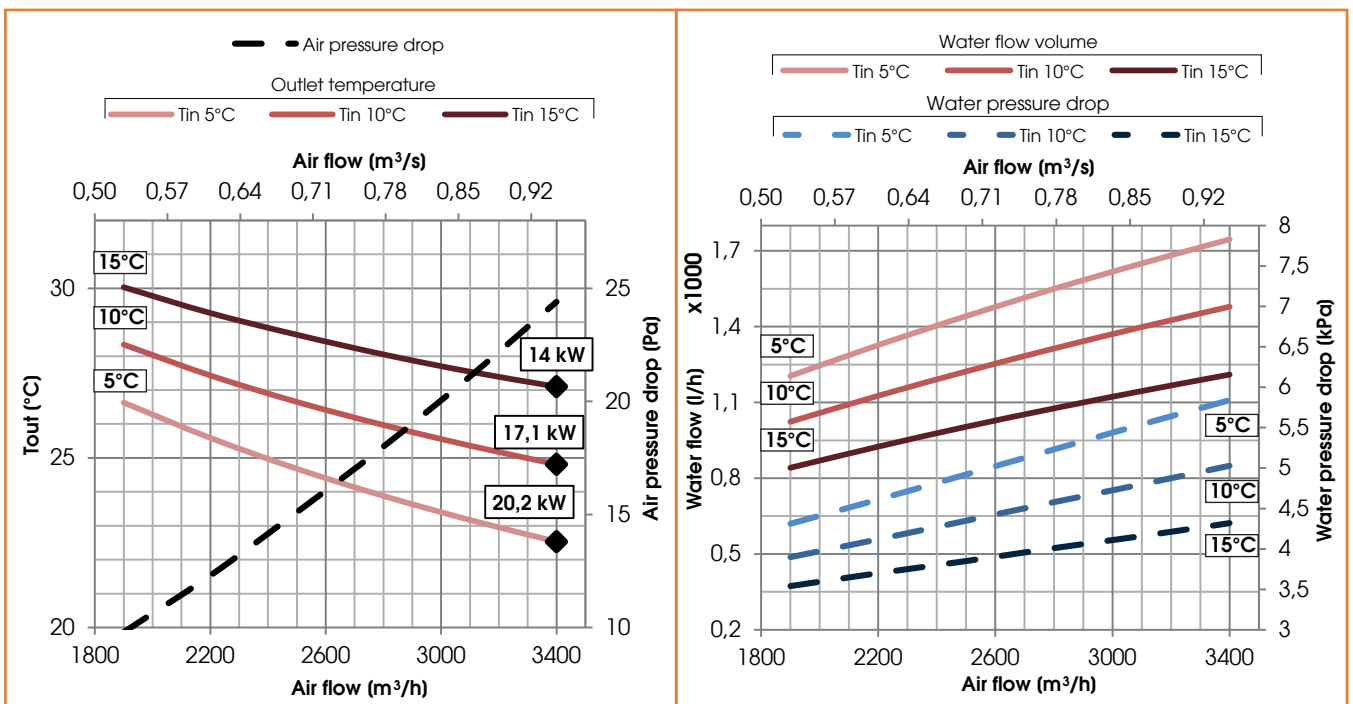



COILS CRHE-V 4500/ENT
Cooling water coil (7°C/12°C)

Ø WATER (”gas)	N. ROWS	FIN PITCH (mm)	INT.VOL. (dm³)	MATERIALS		
				TUBES	FINS	FRAME
1”	3	2,5	8	Cu	Al	Fe Zn

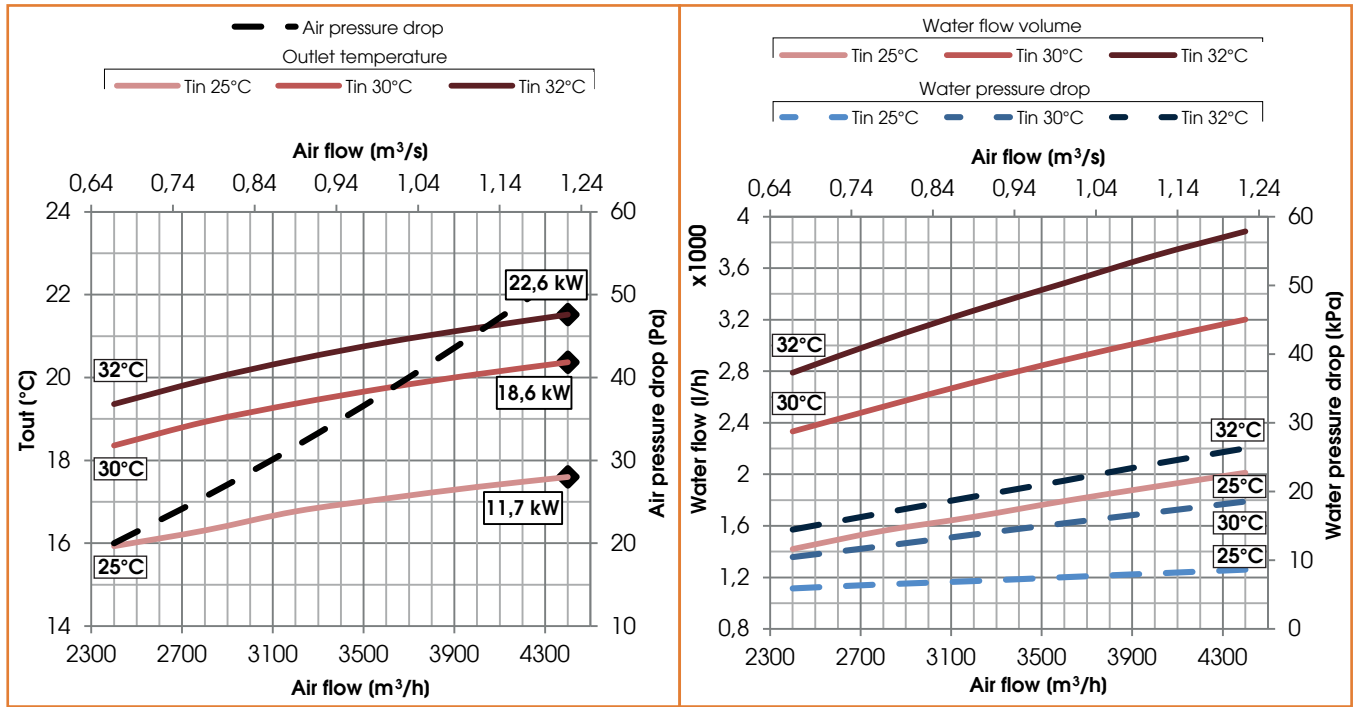

Heating water coil (45°C/35°C)

Ø WATER (”gas)	N. ROWS	FIN PITCH (mm)	INT.VOL. (dm³)	MATERIALS		
				TUBES	FINS	FRAME
1”	3	2,5	8	Cu	Al	Fe Zn

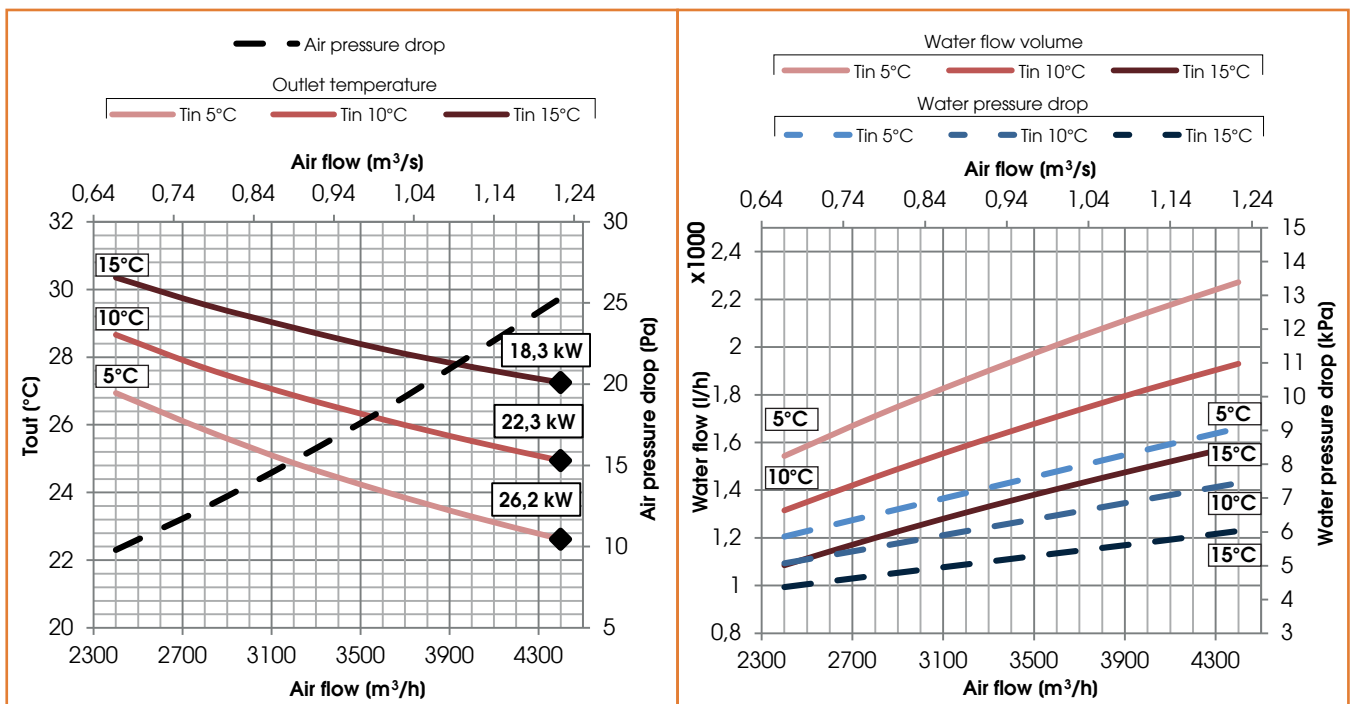



COILS CRHE-V 5600
Cooling water coil (7°C/12°C)

Ø WATER ("gas)	N. ROWS	FIN PITCH (mm)	INT.VOL. (dm³)	MATERIALS		
				TUBES	FINS	FRAME
1"1/4	3	2,5	12	Cu	Al	Fe Zn

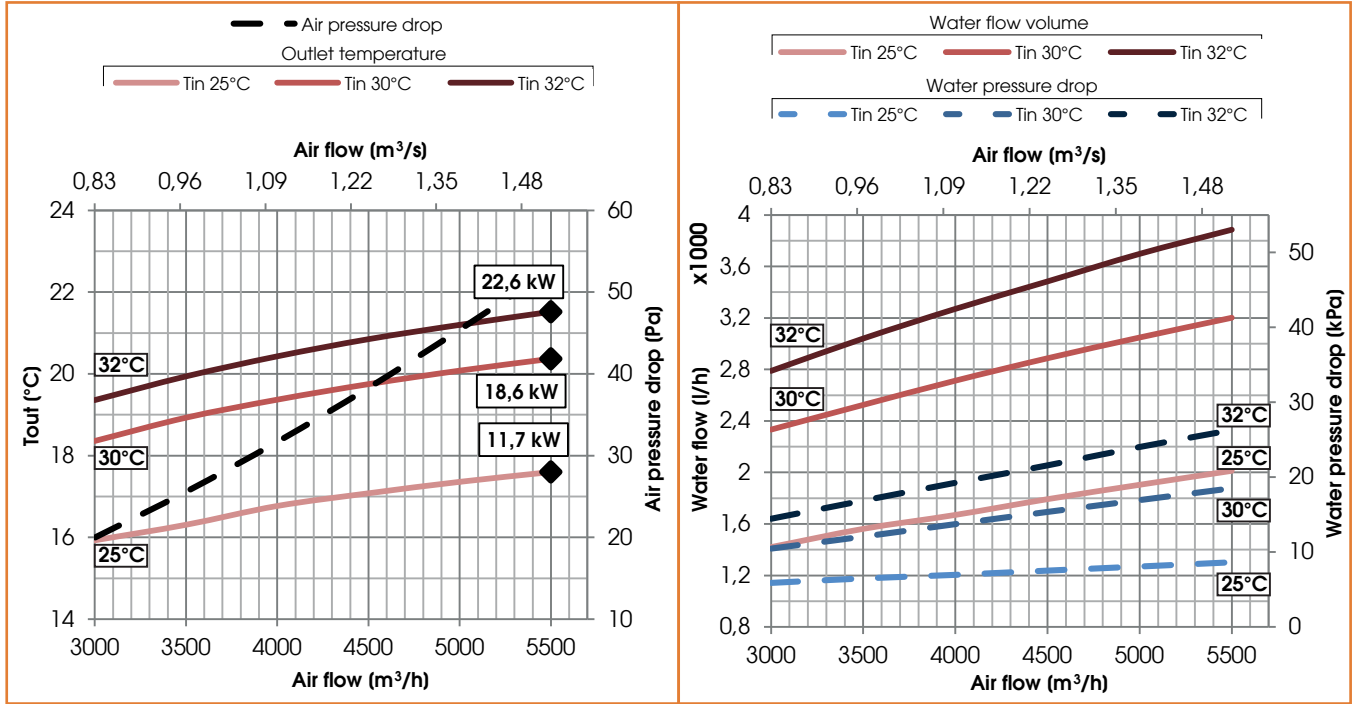

Heating water coil (45°C/35°C)

Ø WATER ("gas)	N. ROWS	FIN PITCH (mm)	INT.VOL. (dm³)	MATERIALS		
				TUBES	FINS	FRAME
1"1/4	3	2,5	12	Cu	Al	Fe Zn

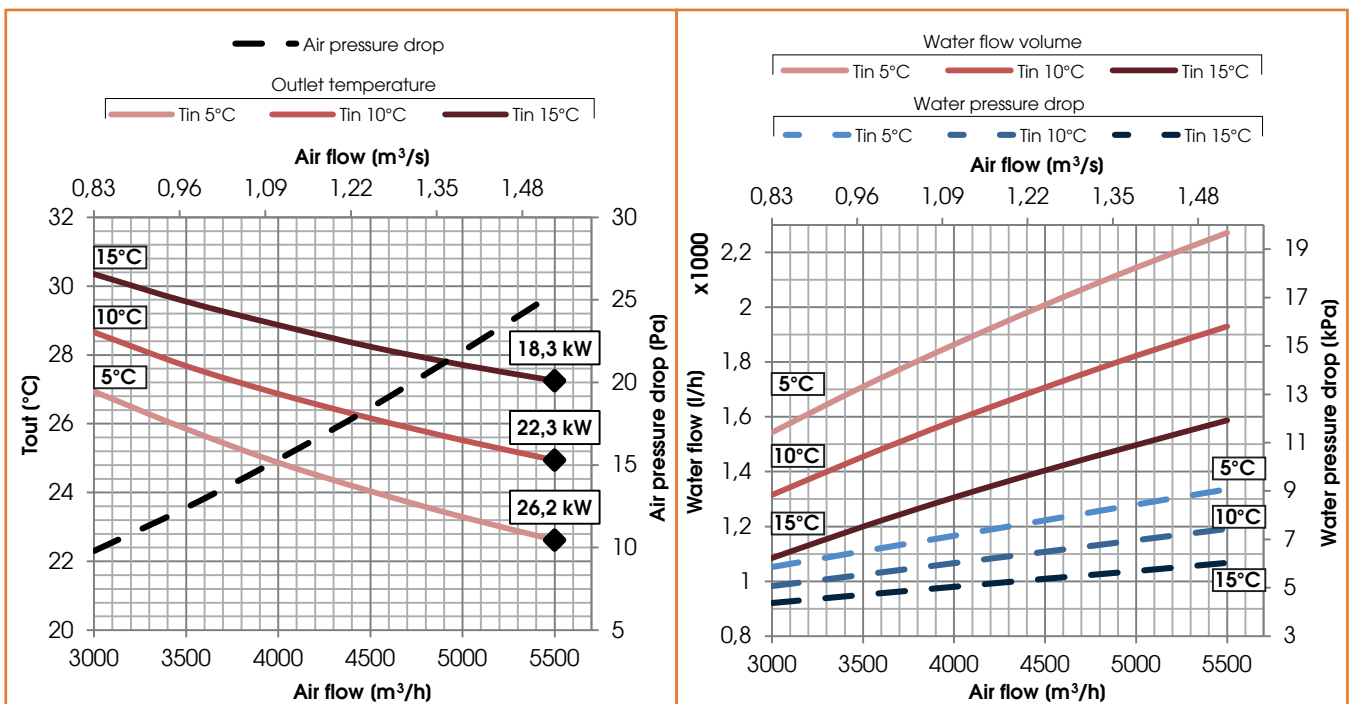



DX coil CRHE-V 700

DIRECT EXPANSION COIL (R410A) TECHNICAL DATA						
Air flow (m³/h)	Tin (C°)	R.H in (%)	Power (kW)	Tout (°C)	R.H: out (%)	Air pressure drop (Pa)
700	28	68	4,8	18	91	60
Ø Connection (mm)	Fin pitch (mm)	N. Rows	Int.Vol. (dm³)	T evap (°C)	T cond (°C)	
22-12	4,0	4	2	5	50	

DX coil CRHE-V 1100

DIRECT EXPANSION COIL (R410A) TECHNICAL DATA						
Air flow (m³/h)	Tin (C°)	R.H in (%)	Power (kW)	Tout (°C)	R.H: out (%)	Air pressure drop (Pa)
1100	28	28	8	18	92	47
Ø Connection (mm)	Fin pitch (mm)	N. Rows	Int.Vol. (dm³)	T evap (°C)	T cond (°C)	
22-12	4,0	4	3	5	50	

DX coil CRHE-V 1600

DIRECT EXPANSION COIL (R410A) TECHNICAL DATA						
Air flow (m³/h)	Tin (C°)	R.H in (%)	Power (kW)	Tout (°C)	R.H: out (%)	Air pressure drop (Pa)
1600	28	68	14	15	100	44
Ø Connection (mm)	Fin pitch (mm)	N. Rows	Int.Vol. (dm³)	T evap (°C)	T cond (°C)	
28-12	2,5	3	3	5	50	

DX coil CRHE-V 2500

DIRECT EXPANSION COIL (R410A) TECHNICAL DATA						
Air flow (m³/h)	Tin (C°)	R.H in (%)	Power (kW)	Tout (°C)	R.H: out (%)	Air pressure drop (Pa)
2500	28	68	17	19	94	70
Ø Connection (mm)	Fin pitch (mm)	N. Rows	Int.Vol. (dm³)	T evap (°C)	T cond (°C)	
28-28	2,5	3	5	5	50	

DX coil CRHE-V 3200

DIRECT EXPANSION COIL (R410A) TECHNICAL DATA						
Air flow (m³/h)	Tin (C°)	R.H in (%)	Power (kW)	Tout (°C)	R.H: out (%)	Air pressure drop (Pa)
3200	28	68	22	19	94	60
Ø Connection (mm)	Fin pitch (mm)	N. Rows	Int.Vol. (dm³)	T evap (°C)	T cond (°C)	
28-22	2,5	3	6	5	50	

DX coil CRHE-V 4500

DIRECT EXPANSION COIL (R410A) TECHNICAL DATA						
Air flow (m³/h)	Tin (C°)	R.H in (%)	Power (kW)	Tout (°C)	R.H: out (%)	Air pressure drop (Pa)
4500	28	68	35	18	92	101
Ø Connection (mm)	Fin pitch (mm)	N. Rows	Int.Vol. (dm³)	T evap (°C)	T cond (°C)	
42-28	2,5	4	10	5	50	

DX coil CRHE-V 5600

DIRECT EXPANSION COIL (R410A) TECHNICAL DATA						
Air flow (m³/h)	Tin (C°)	R.H in (%)	Power (kW)	Tout (°C)	R.H: out (%)	Air pressure drop (Pa)
5600	29	70	44	18,5	95	51
Ø Connection (mm)	Fin pitch (mm)	N. Rows	Int.Vol. (dm³)	T evap (°C)	T cond (°C)	
42-35	2,5	3	11	5	50	

Electrical heater

PRE-POST ELECTRICAL HEATER TECHNICAL DATA				
Unit	Power supply	Power (kW)	Current (A)	N. stages
CRHE-V 700	230V, 50Hz,1F	2	8,7	1
CRHE-V 1100	230V, 50Hz,1F	3	13,0	1
CRHE-V 1600	230V, 50Hz,1F	6	26,1	1
CRHE-V 2500	230V, 50Hz,1F	6	26,0	1
CRHE-V 3200*	230V, 50Hz,1F	8	34,7	1
CRHE-V 3200	400V, 50Hz,3F	8	11,5	1
CRHE-V 4500	400V, 50Hz,3F	12	17,3	1
CRHE-V 5600	400V, 50Hz,3F	16	23,0	1

*Pre-heating batteries are always Tri-phase. For other batteries PRE or POST treatment see the Techno-list of ACCESSORIES

A	Manufacturer's name	C.L.A. S.r.l.							
B	Manufacturer's model identifier		CRHE 700EC BP EVO-PH SV	CRHE 1100EC BP EVO-PH SV	CRHE 1600EC BP EVO-PH SV	CRHE 2500EC BP EVO-PH SV			
C	Declared typology		UVNR / UVB	UVNR / UVB	UVNR / UVB	UVNR / UVB			
D	Type of drive installed		Variable speed drive	Variable speed drive	Variable speed drive	Variable speed drive			
E	Type of HRS		other	other	other	other			
F	Thermal efficiency of heat recovery (%)		82,2	82,2	82,7	84,6			
G	Nominal NRUV flow rate (m³/s)		0,161	0,254	0,47	0,597			
H	Effective electric power input (kW)		0,29	0,33	0,95	0,82			
I	SFPint (W/(m³/s))		842	461	1103	569			
J	Face velocity at design flow rate (m/s)		1,2	1,3	1,5	1,5			
K	Nominal external pressure (Pa)		200	200	200	200			
L	Internal pressure drop of ventilation components (Pa)		475	278	697	344			
M	Optional: internal pressure drop of non-ventilation components		-	-	-	-			
N	Static efficiency of fans used in accordance with Regulation (EU) No 327/2011 (%)		56,5	58,5	63,2	55,4			
O	Declared maximum external leakage rate of the casing of ventilation units (%)		5,4	4,6	2,9	4,0			
	Declared maximum internal leakage rate of bidirectional ventilation units or carry over (for regenerative heat exchangers only) (%)		9,5	7,1	4,5	4,6			
P	Energy performance, preferably energy classification, of the filters (declared information about the calculated annual energy consumption)		ePM1 70% (F7) ePM10 50% (M5)	ePM1 70% (F7) ePM10 50% (M5)	ePM1 70% (F7) ePM10 50% (M5)	ePM1 70% (F7) ePM10 50% (M5)			
Q	Position and description of visual filter warning for RVUs intended for use with filters, including text pointing out the importance of regular filter changes for performance and energy efficiency of the unit		Filter warning is signalled on the display of the control system: the flashing writing "DirtyFilters" will appear. "To preserve the energy efficiency of the NRUV, it's recommended to replace the filters when signaled." Positioned near the filters inspection						
R	Casing sound power level (LWA) (dB)		52	51	59	60			
S	Internet address for pre-/dis-assembly instructions		www.utek-air.it						

A	Manufacturer's name	C.L.A. S.r.l.	CRHE 3200EC BP EVO-PH SV	CRHE 4500EC BP EVO-PH SV	CRHE 5600EC BP EVO-PH SV
B	Manufacturer's model identifier		UVNR / UVB	UVNR / UVB	UVNR / UVB
C	Declared typology		Variable speed drive	Velocità variabile	Velocità variabile
D	Type of drive installed		other	altro	altro
E	Type of HRS		85,0	84,9	85,6
F	Thermal efficiency of heat recovery (%)		0,825	1,129	1,453
G	Nominal NRVU flow rate (m³/s)		1,47	2,59	2,88
H	Effective electric power input (kW)		695	1040	781
I	SFPint (W)/(m³/s)		1,5	2,0	1,8
J	Face velocity at design flow rate (m/s)		200	250	250
K	Nominal external pressure (Pa)		299	480	370
L	Internal pressure drop of ventilation components (Pa)		-	-	-
M	Optional: internal pressure drop of non-ventilation components				
N	Static efficiency of fans used in accordance with Regulation (EU) No 327/2011 (%)		48,3	51,4	54,0
O	Declared maximum external leakage rate of the casing of ventilation units (%)		4,2	3,6	3,0
	Declared maximum internal leakage rate of bidirectional ventilation units or carry over (for regenerative heat exchangers only) (%)		3,5	2,8	2,3
P	Energy performance, preferably energy classification, of the filters (declared information about the calculated annual energy consumption)		ePM1 70% (F7) ePM10 50% (M5)	ePM1 70% (F7) ePM10 50% (M5)	ePM1 70% (F7) ePM10 50% (M5)
Q	Position and description of visual filter warning for RVUs intended for use with filters, including text pointing out the importance of regular filter changes for performance and energy efficiency of the unit		Filter warning is signaled on the display of the control system; the flashing writing "DirtyFilters" will appear. "To preserve the energy efficiency of the NRVU, it's recommended to replace the filters when signaled." Positioned near the filters inspection		
R	Casing sound power level (LWA) (dB)		63	68	73
S	Internet address for pre-/dis-assembly instructions		www.utek-air.it		

CLA & UTEK reserves the right to at any time the necessary changes to improve products without prior notice .

Dear Customer

Thanks for your attention to the product UTEK , designed and manufactured to ensure the real values to the User : Quality, Safety and Savings on working.



Made in Italy

**AZIENDA CON SISTEMA
DI GESTIONE QUALITÀ
CERTIFICATO DA DNV GL
ISO 9001**

**AZIENDA CON
SISTEMA DI GESTIONE
AMBIENTALE CERTIFICATO
DA DNV
ISO 14001**



the Dealer

CRHE-V_2018_5_EN
Validity from 20/09/2022



VENTILATION UNIT WITH HEAT RECOVERY FOR COMMERCIAL AND INDUSTRIAL BUILDINGS