



indoor air quality and energy saving

TECHNICAL DATA



UVR & UVR-TOP



HEAT RECOVERY VENTILATION UNITS for COMMERCIAL and INDUSTRIAL BUILDINGS



UVR & UVR-TOP

Non-residential ventilator unit with dual flow and high yield heat recovery.

PERFORMANCE

Equipped with a rotary enthalpic heat exchanger (rotary recuperator) in aluminium (Eurovent certified) and electronic backward blade ventilators.

STRUCTURE

UVR & UVR-TOP are manufactured using a profiled extruded aluminium frame and 45 mm thick sandwich panels, insulated in polyurethane foam. The panels and inner parts are manufactured in zinc magnesium, material that ensures high strength against corrosion and oxidation. A pair of panels with hinged opening eases access to the filters ePM1 55% (F7) for the renewed air flow and ePM10 50% (M5) for the extraction air flow). UVR & UVR-TOP are designed to be installed inside or outside buildings (UVR-TOP, if installed outside, must be installed under cover); it is supplied with 100 mm high aluminium bases for installation on the floor. Equipped with an **ENTHALPIC** rotary heat exchanger (regenerative recuperator) in aluminum (Eurovent certified), available on request also in ABSORPTION version with greater efficiency of humidity recovery; Available in 6 sizes and 2 versions: the standard version T3 TB3 and, **on request**, the version with thermal break T2 TB2. The units can be equipped with air post-treatment systems, inside or outside the unit, such as: hot water battery, electrical heater with variable speed. If the post treatment is external, modules similar to the unit are added.

CONTROLS

UVR & UVR-TOP was supplied with an electric box and control system; it is available in a version equipped with EVO-PH control and a version equipped with EVOD-PH-IP control prepared for complete integration in home automation systems (Modbus protocol with Ethernet connection or, on request, with the addition of connection RS485). The new version of our control systems enables extremely easy and rapid passage from a control system to another, even after installation with the single replacement of the remote panel.

The EVO-PH control has a coloured, backlit touch screen interface with intuitive viewing of the working status of the machine. It enables precise adjustment of ventilator speed and has a weekly, time schedule for automatic management of the ventilators. It can be controlled by an external switch to activate the booster function, it can automatically adjust the air flow rate if connected to an air quality probe, it can manage any air post treatment accessories, it automatically manages the bypass and prevents heat exchanger freezing by managing the speed of the ventilators or, if installed, an electrical pre-heating resistor (optional accessory outside the machine); it signals to the user the need to replace the filters (the clogging status of the filters is monitored by a pair of different pressure switches, supplied as standard) or an anomaly, indicating the origin. With the addition of optional accessories (COP kit and CAV kit installed on the channel) you can manage the ventilation machine in constant pressure or constant flow rate mode.

The EVOD-PH-IP control has the same characteristics as the EVO-PH version with the addition of Modbus communication protocol which allows full control of the machine by the supervision software of the home automation system. The implemented webserver allows interaction with the machine, even with an internet browser of a device connected (even from remote) to the home automation system in which the machine is inserted.

ACCESSORIES

The units can be equipped with other accessories such as:

- . Available roof only for UVR unit
- . R.H. of probe, CO2 or CO2/VOC
- . Operating kit pressure or constant flow
- . grilles and damper

For a more complete view of the characteristics of the control panels, please read the specific manuals

UVR-TOP 1 and 2 standard and mirrored configuration

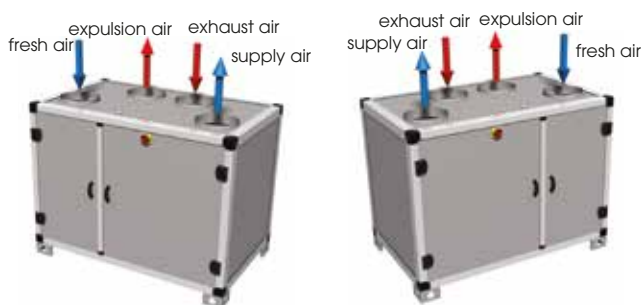

UVR 1 and 2 standard and mirrored configuration

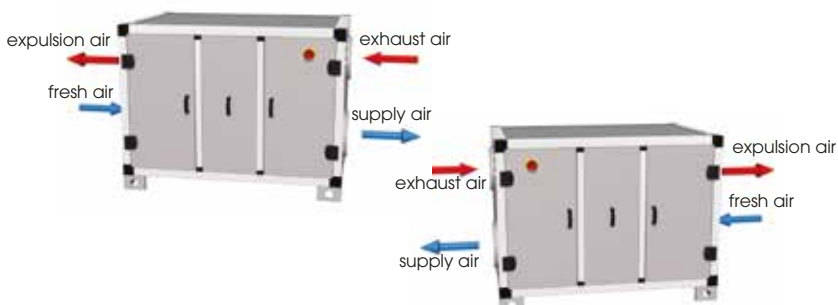

UVR-TOP from size 3 to 6 standard and mirrored configuration

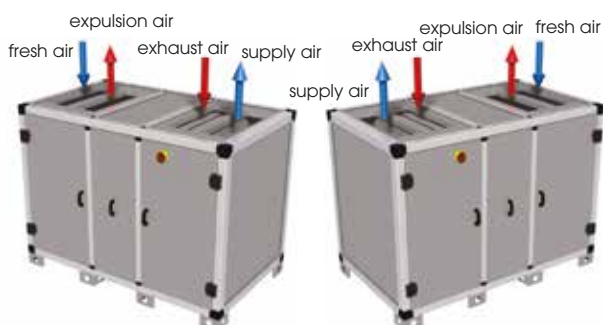

UVR from size 3 to 6 standard and mirrored configuration

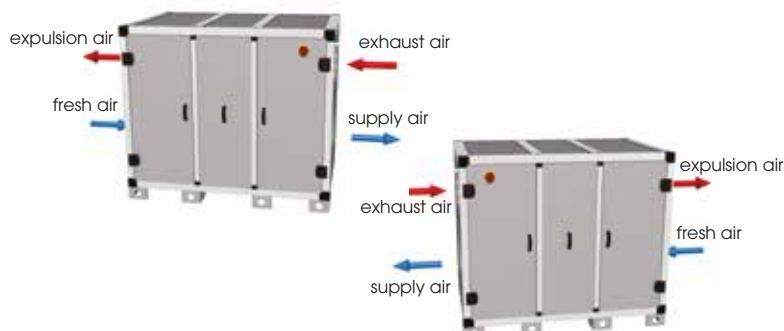

Rotary heat exchanger made of aluminum manufactured by KLINGENBURG
KLINGENBURG participates in the Eurovent Certification Program



PERFORMANCES (UNI EN 13141-7)

The unit must be ducted properly: UTEK authorizes the use only according to its performance diagram shown into this catalogue
The declared performances are with CLEAN filters, and guaranteed ONLY with the original filters UTEK low pressure drop.

UVR & UVR-TOP 1

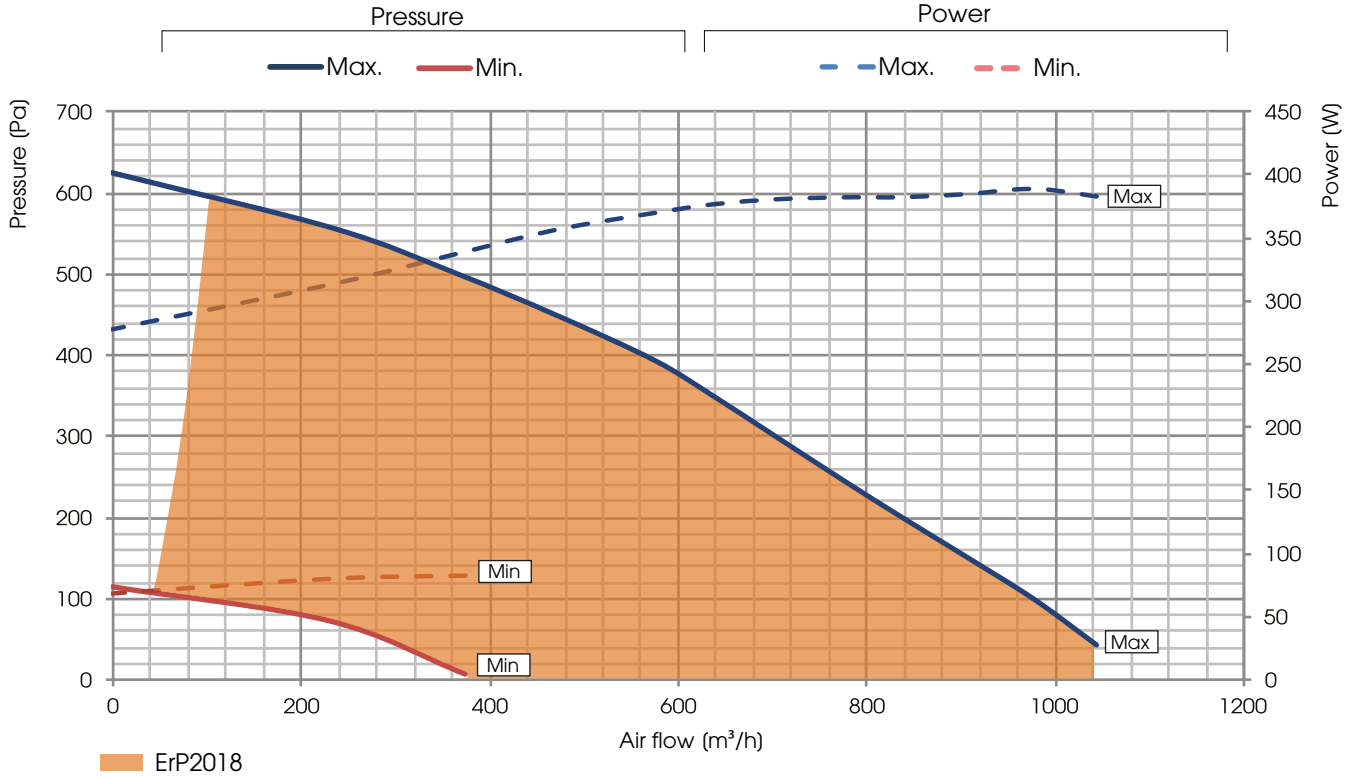

UVR & UVR-TOP 2

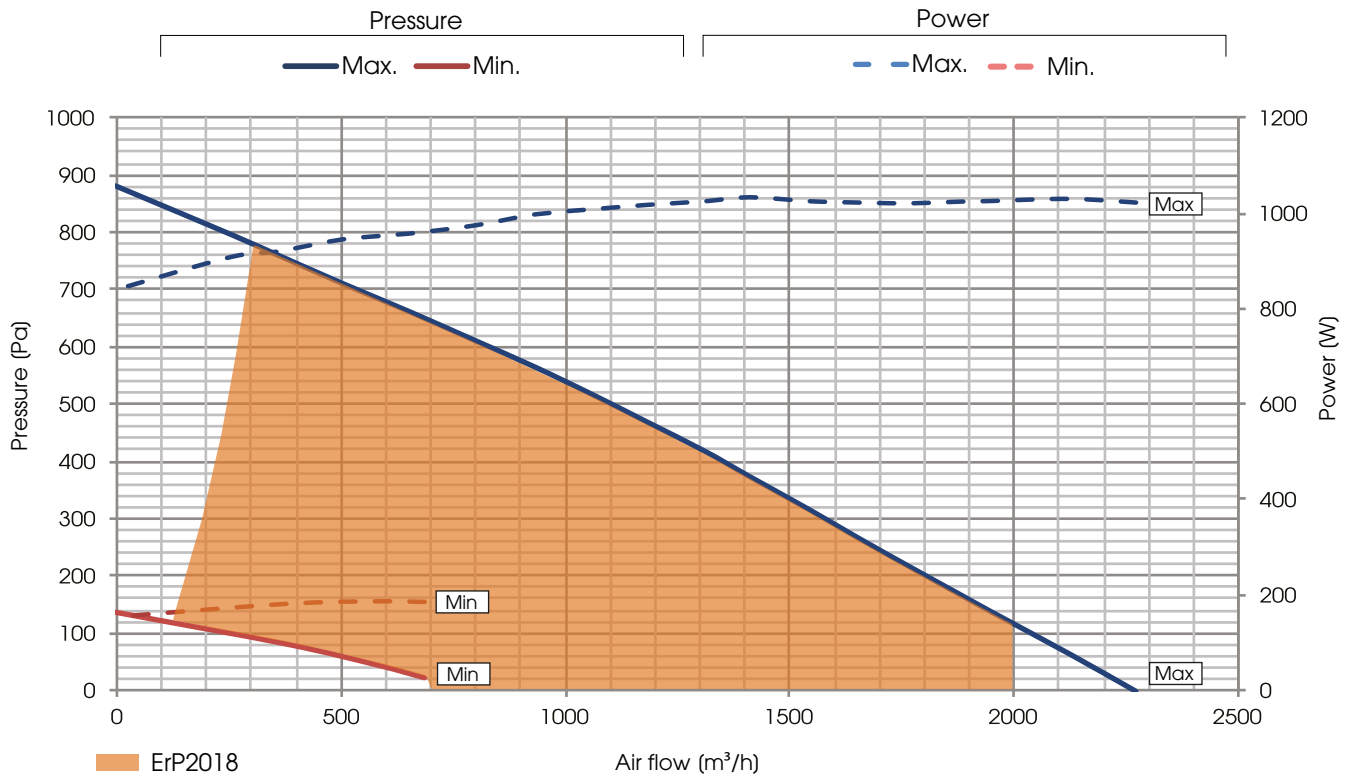



PERFORMANCES (UNI EN 13141-7)

The unit must be ducted properly: UTEK authorizes the use only according to its performance diagram shown into this catalogue
The declared performances are with CLEAN filters, and guaranteed ONLY with the original filters UTEK low pressure drop.

UVR & UVR-TOP 3

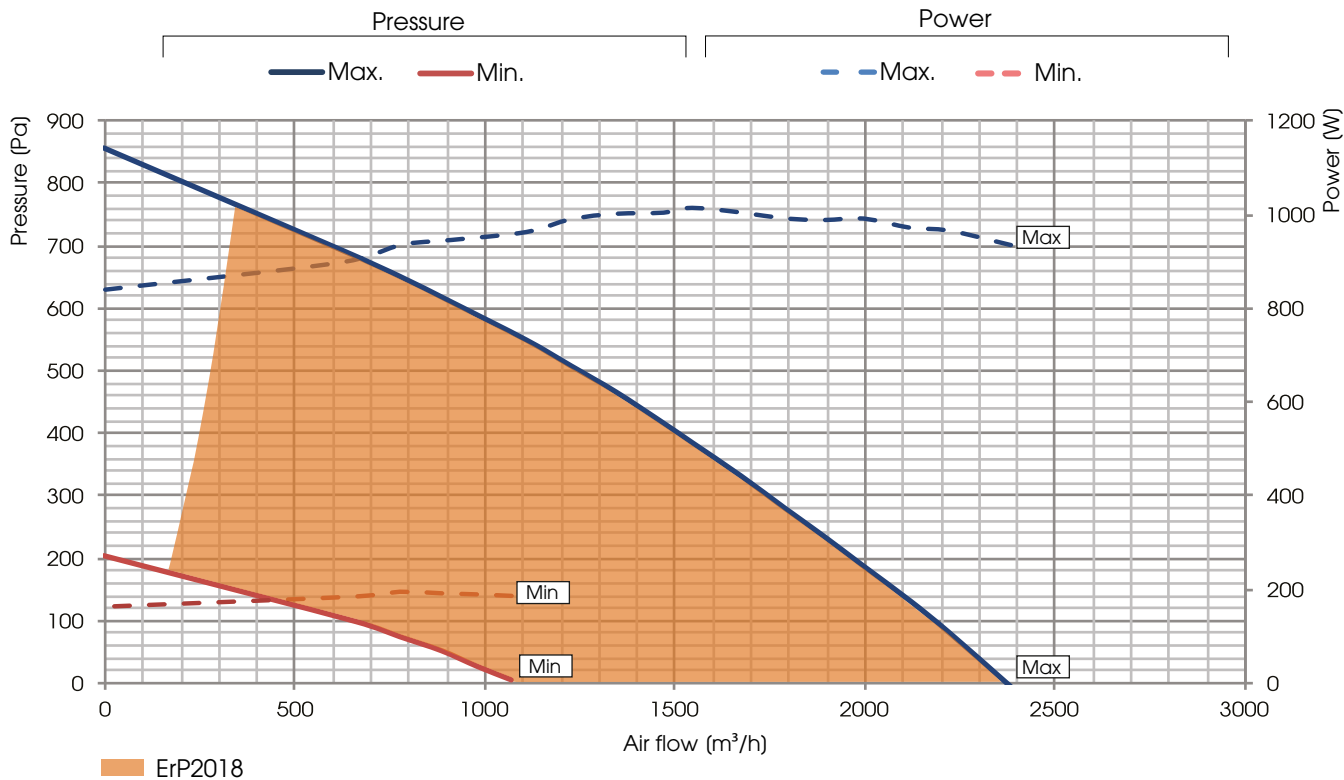

UVR & UVR-TOP 4

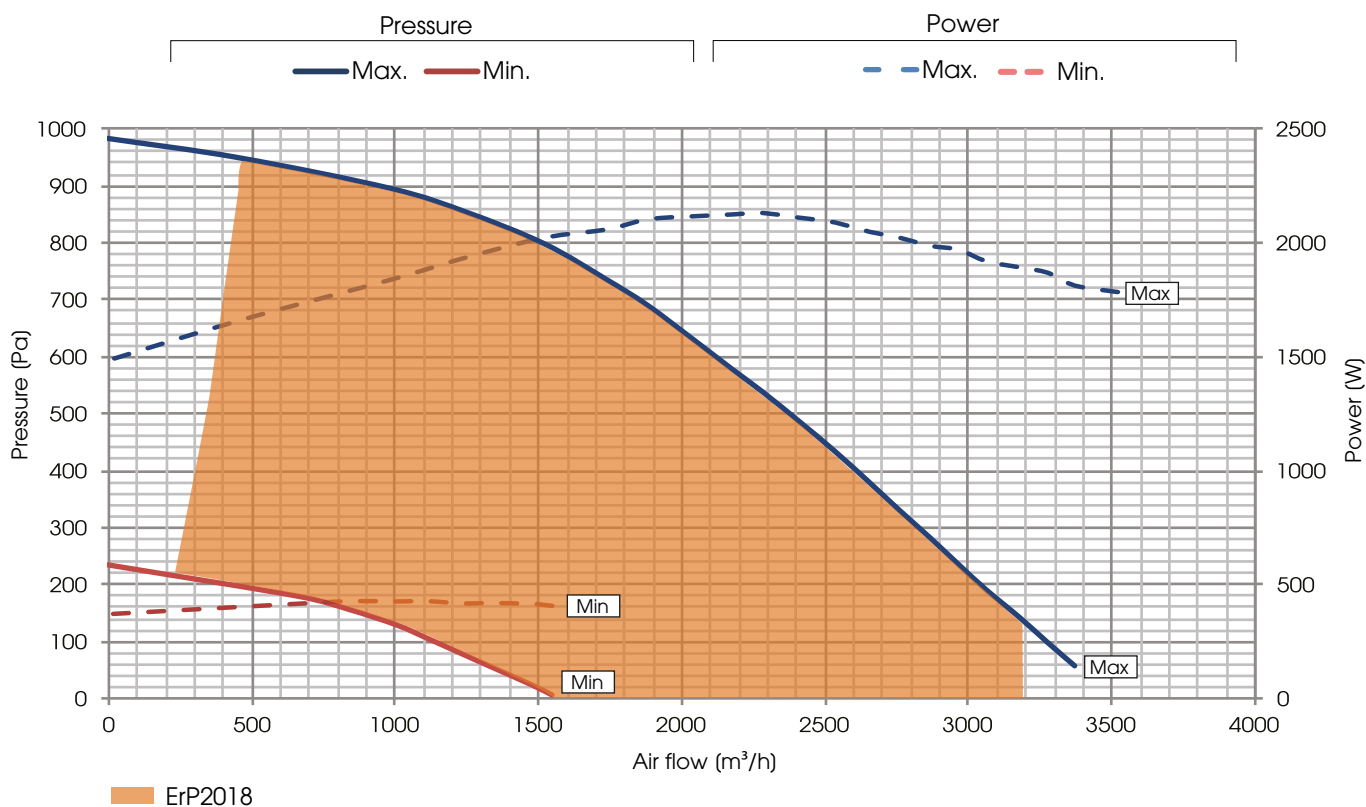



PERFORMANCES (UNI EN 13141-7)

The unit must be ducted properly: UTEK authorizes the use only according to its performance diagram shown into this catalogue
The declared performances are with CLEAN filters, and guaranteed ONLY with the original filters UTEK low pressure drop.

UVR & UVR-TOP 5

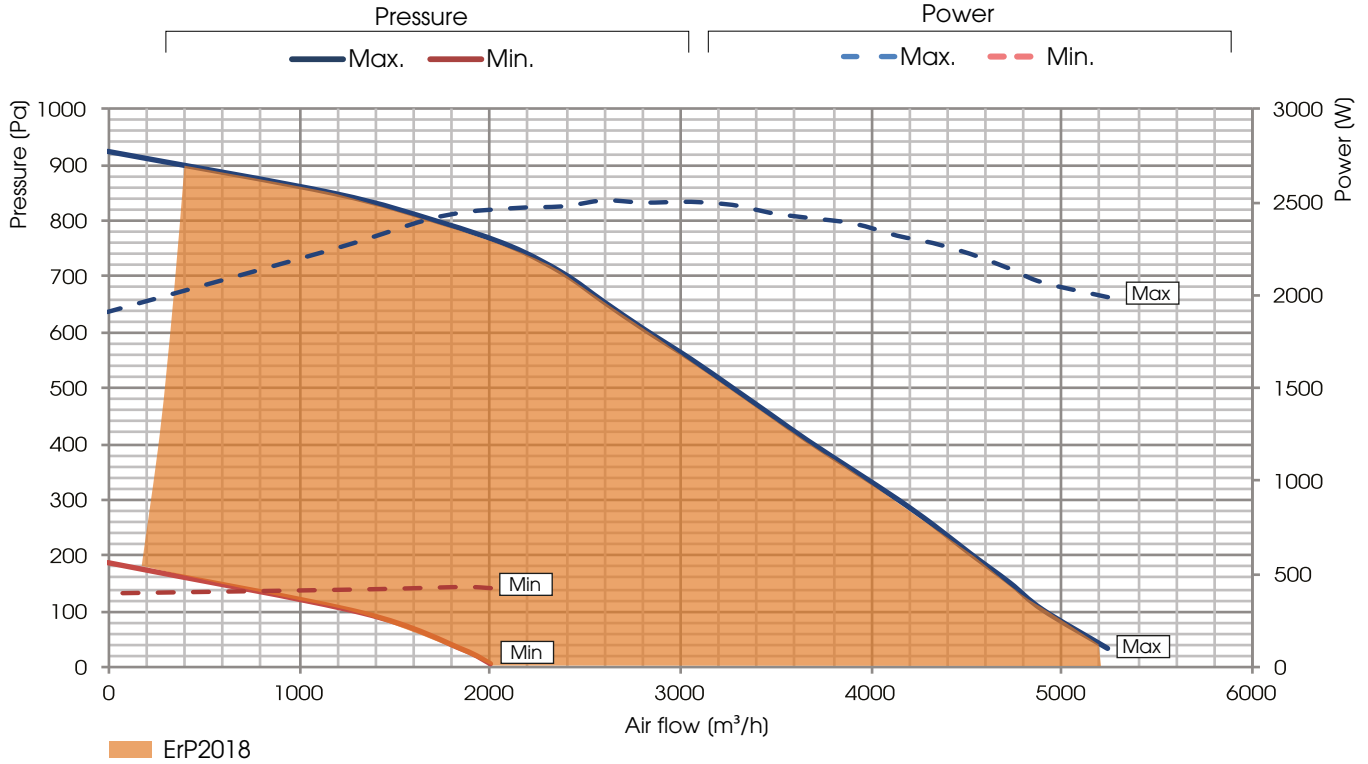

UVR & UVR-TOP 6

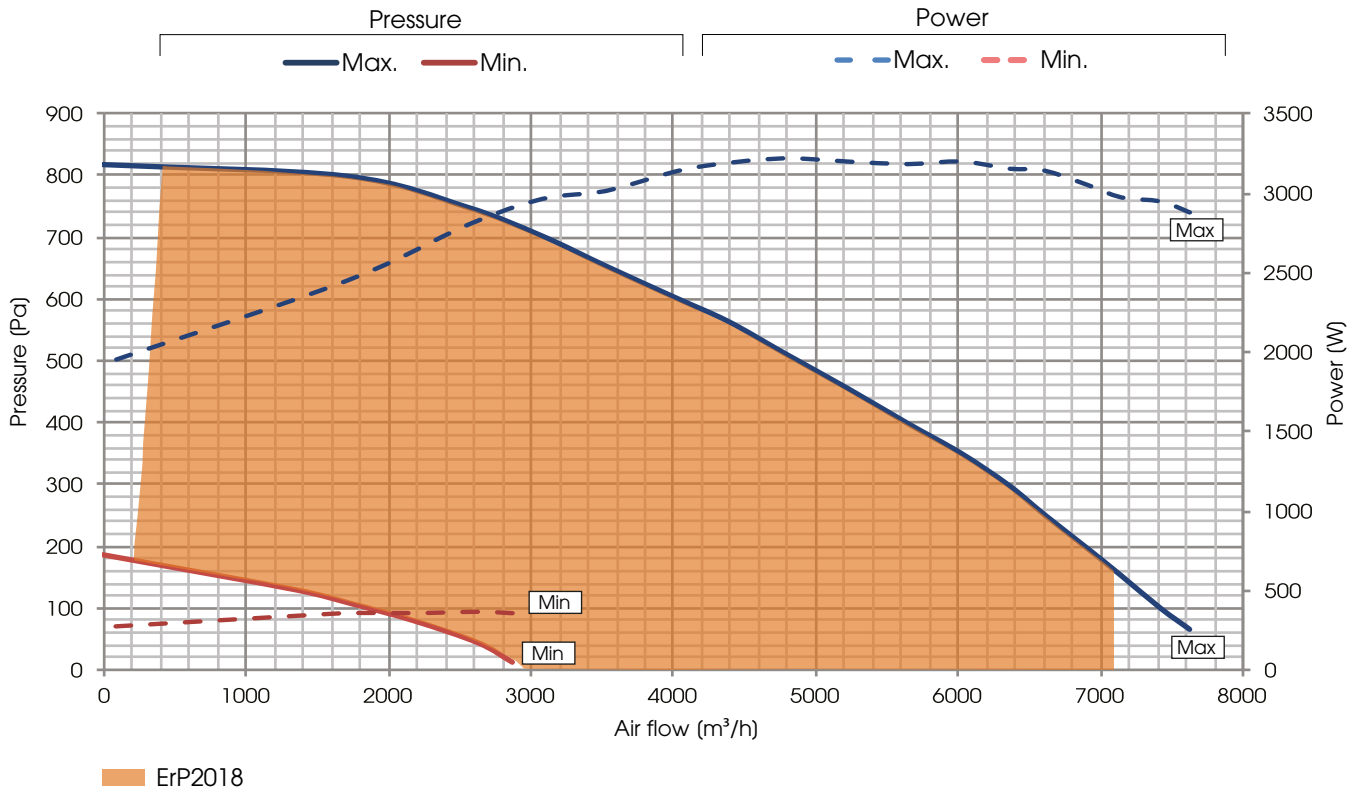



HEAT RECOVERY PERFORMANCE (sensible efficiency) / TEMPERATURE (*)

Values referred to the following conditions (UNI EN 308:1998): Tbs external air 5°C; U.R. external 72%; Tbs environment 25°C; U.R. environment 38%

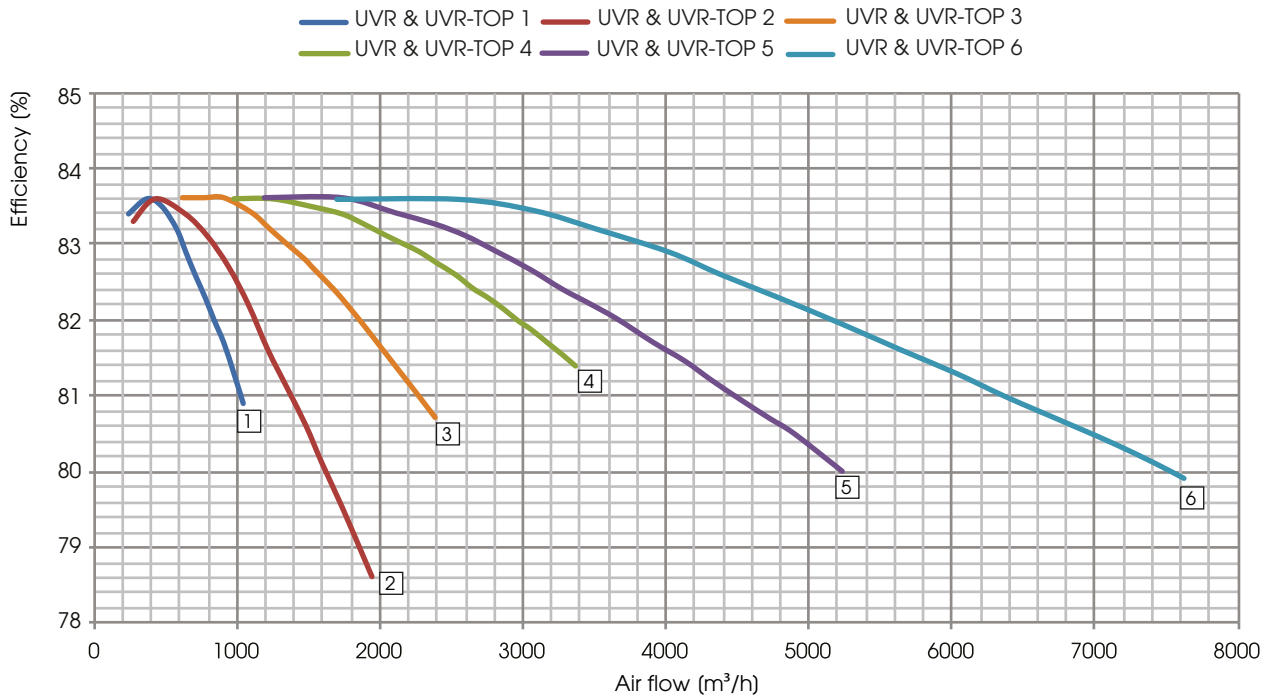

(*) contact us for the RECOVERY EFFICIENCY OF LATENT HEAT / HUMIDITY (*)

ECODESIGN

UNIT	$\eta_{t,nvru}$ (%)	q_{nom} (m³/s)	$\Delta p_{s,ext}$ (Pa)	P(kW)	SFP _{int} (W/(m³/s))	SFP _{int,lim 2016} (W/(m³/s))	SFP _{int,lim 2018} (W/(m³/s))	SPEED FRONT (m/s)	$\Delta p_{s,int}$ (Pa)	η_{Fan} (%)	* Internal LEAKAGE (%)	* External LEAKAGE (%)
UVR & UVR-TOP 1	81,2	0,27	100	0,35	804	1585	1305	1,09	434	53,8	-	4,3
UVR & UVR-TOP 2	78,2	0,57	100	0,95	1101	1451	1171	1,54	525	48,8	-	2,0
UVR & UVR-TOP 3	81,2	0,61	100	0,92	908	1534	1254	1,16	392	43,3	-	2,2
UVR & UVR-TOP 4	81,7	0,88	150	1,71	1212	1510	1230	1,25	629	52,1	-	2,0
UVR & UVR-TOP 5	80,5	1,36	100	2,13	1008	1400	1120	1,95	558	60,0	-	1,4
UVR & UVR-TOP 6	80,6	1,91	200	2,19	1013	1322	1042	2,19	816	70,0	-	1,7

* Compared to q_{nom}

VALUES ACCORDING UNI EN 1886: 2008

UNIT	CASING STRENGTH	CASING LEAKAGE	FILTER CLASS	THERMAL TRANSMITTANCE	THERMAL BRIDGE
UVR & UVR-TOP 1	D1 (M)	L3 (M)	F7 (M)	T3 (M)	TB3 (M)
UVR & UVR-TOP 2	D1 (M)	L3 (M)	F7 (M)	T3 (M)	TB3 (M)
UVR & UVR-TOP 3	D1 (M)	L3 (M)	F7 (M)	T3 (M)	TB3 (M)
UVR & UVR-TOP 4	D1 (M)	L3 (M)	F7 (M)	T3 (M)	TB3 (M)
UVR & UVR-TOP 5	D1 (M)	L3 (M)	F7 (M)	T3 (M)	TB3 (M)
UVR & UVR-TOP 6	D1 (M)	L3 (M)	F7 (M)	T3 (M)	TB3 (M)

TEST LEAKAGE (UNI EN 13141-7)

LEAKAGE	TEST CONDITIONS	LEAKAGE CLASSIFICATION					
		UVR & UVR-TOP 1	UVR & UVR-TOP 2	UVR & UVR-TOP 3	UVR & UVR-TOP 4	UVR & UVR-TOP 5	UVR & UVR-TOP 6
EXTERNAL	Positive pressure 400 Pa	A2	A2	A1	A1	A1	A1
EXTERNAL	Negative pressure 400 Pa	A2	A2	A1	A1	A1	A1
INTERNAL	Pressure difference 250 Pa	ND	ND	ND	ND	ND	ND



NOISE LEVEL

Lw Sound power level taken in accordance to UNI EN ISO 3747 - CLASS 3

	NOISE FROM THE CASE (dB)							
	125 Hz	250 Hz	500 Hz	1000 Hz	2000 Hz	4000 Hz	8000 Hz	L _w dB(A)
UVR & UVR-TOP 1	63,2	68,9	63,9	59,2	55,3	50,0	53,3	65,9
UVR & UVR-TOP 2	74,0	76,5	68,5	62,6	59,2	49,0	51,2	71,3
UVR & UVR-TOP 3	72,0	76,0	68,5	64,7	60,0	52,5	56,2	71,5
UVR & UVR-TOP 4	83,2	78,6	75,2	68,7	63,6	57,1	59,9	76,3
UVR & UVR-TOP 5	80,4	79,7	71,2	63,1	57,8	54,8	56,8	74,1
UVR & UVR-TOP 6	77,6	80,8	72,4	66,3	59,0	57,8	57,3	75,1

	NOISE IN THE DUCT (dB)							
	125 Hz	250 Hz	500 Hz	1000 Hz	2000 Hz	4000 Hz	8000 Hz	L _w dB(A)
UVR & UVR-TOP 1	63,8	73,8	69,0	63,6	62,6	60,4	69,9	73,2
UVR & UVR-TOP 2	68,0	89,2	80,3	72,9	69,4	67,5	70,2	83,3
UVR & UVR-TOP 3	67,7	82,2	78,4	69,6	66,4	67,1	69,5	79,2
UVR & UVR-TOP 4	71,9	88,3	86,3	82,5	77,4	75,7	81,0	88,4
UVR & UVR-TOP 5	77,9	85,2	79,8	75,4	67,4	70,5	74,3	82,3
UVR & UVR-TOP 6	84,8	84,7	79,2	72,2	68,6	72,4	69,2	81,6

ELECTRICAL DATA

MATCHING	FAN				UNIT UVR-TOP		
	Power (W)	Supply	Max current.(A)	Insulation class	Supply	Max current.(A)	Insulation class
UVR & UVR-TOP 1	2 x 170	230V 50 Hz 1F	2 x 1,4	IP54 CLASS B	230V 50 Hz 1F	2,9	IP 20
UVR & UVR-TOP 2	2 x 448	230V 50 Hz 1F	2 x 2,8	IP54 CLASS B	230V 50 Hz 1F	6,5	IP 20
UVR & UVR-TOP 3	2 x 448	230V 50 Hz 1F	2 x 2,8	IP54 CLASS B	230V 50 Hz 1F	6,1	IP 20
UVR & UVR-TOP 4	2 x 1000	400V 50 Hz 3F	2 x 1,6	IP54 CLASS B	400V 50 Hz 3F	3,8	IP 20
UVR & UVR-TOP 5	2 x 1100	400V 50 Hz 3F	2 x 1,7	IP55 CLASS F	400V 50 Hz 3F	4,4	IP 20
UVR & UVR-TOP 6	2 x 1740	400V 50 Hz 3F	2 x 2,7	IP54 CLASS B	400V 50 Hz 3F	5,5	IP 20

DIMENSIONS (mm) WEIGHT (kg)

UVR-TOP size 1 and 2

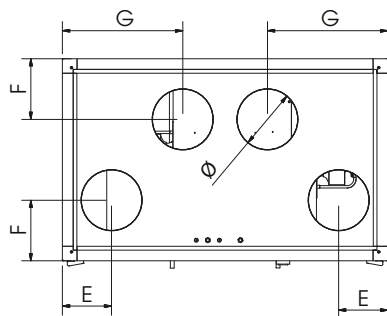
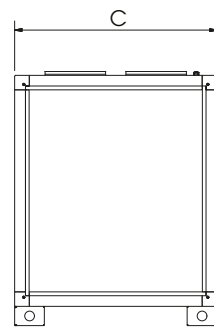
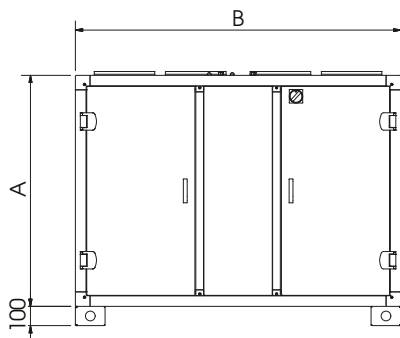

UNIT	Dimensions (mm)							Weight (kg)
	A	B	C	Ø	E	F	G	
UVR-TOP 1	1120	1450	808	250	212	257	532	190
UVR-TOP 2	1200	1690	1050	315	255	315	625	240



UVR-TOP from size 3 to 6

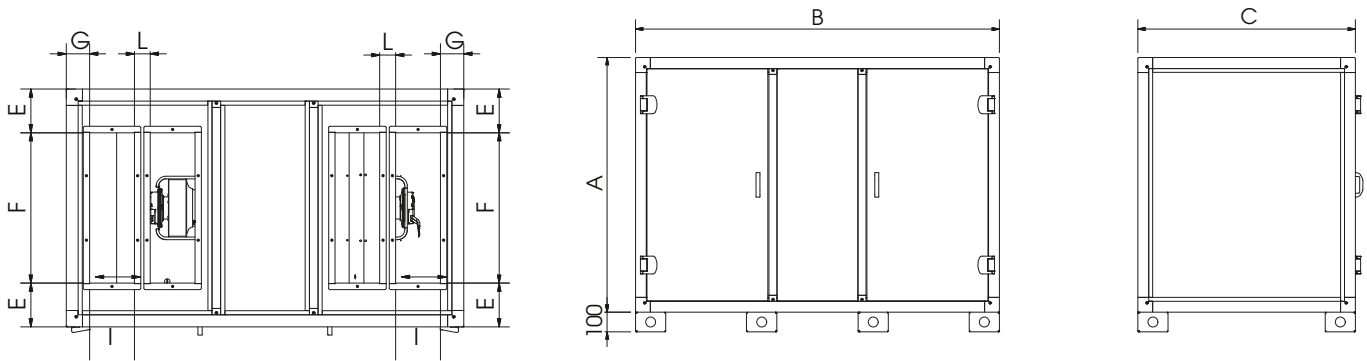

MODEL	Dimensions (mm)								Weight (kg)
	A	B	C	E	F	G	I	L	
UVR-TOP 3	1294	1850	1106	203	700	109	208	74	300
UVR-TOP 4	1405	2000	1356	178	1000	119	208	74	350
UVR-TOP 5	1530	2300	1482	241	1000	109	308	66	400
UVR-TOP 6	1780	2600	1732	266	1200	119	308	120	530

DIMENSIONS (mm) WEIGHT (kg) UVR size 1 and 2

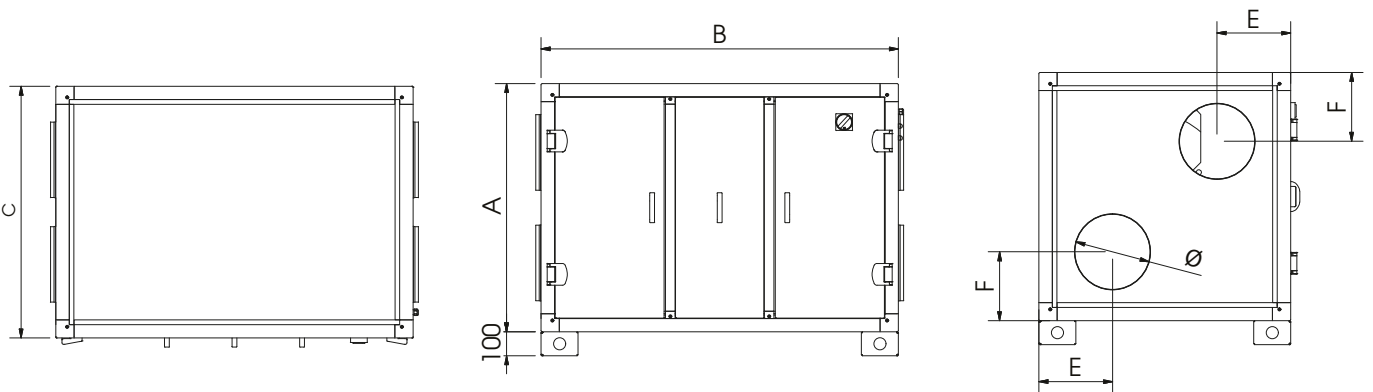

MODEL	Dimensions (mm)							Weight (kg)
	A	B	C	Ø	E	F		
UVR 1	923	1344	808	250	277	257	160	
UVR 2	1035	1490	1056	315	307	287	200	

Dimensions UVR from size 3 to 6

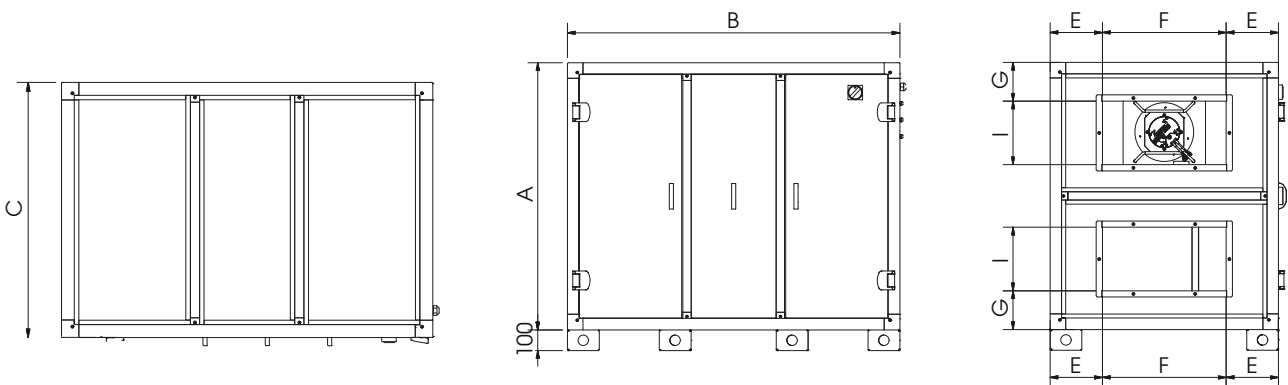

MODEL	Dimensions (mm)							
	A	B	C	E	F	G	I	Weight (kg)
UVR 3	1294	1610	1106	253	600	188	308	260
UVR 4	1405	1700	1356	328	700	165	408	320
UVR 5	1530	2020	1482	341	800	196	408	390
UVR 6	1780	2400	1732	366	1000	209	508	520



Dimensions of UVR and UVR-TOP divided into blocks
from size 3 to 6

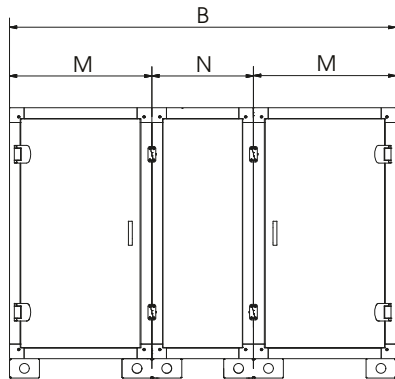

MODEL	Dimensions (mm)		
	B	M	N
UVR 3	1753	614	525
UVR 4	1843	634	575
UVR 5	2163	779	605
UVR 6	2543	914	715
UVR-TOP 3	1993	734	525
UVR-TOP 4	2143	784	575
UVR-TOP 5	2443	919	605
UVR-TOP 6	2743	1014	715

INSTALLATION

HORIZONTAL FLOOR INSTALLATION

■ Minimum maintenance spaces (mm)

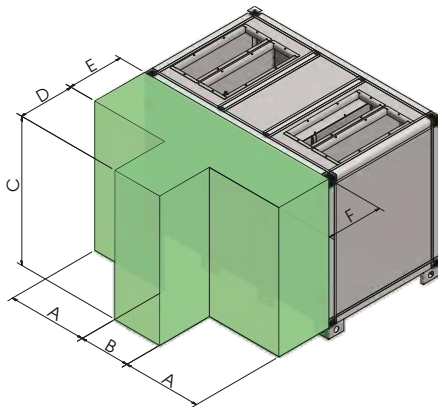

UNIT	Dimensions (mm)					
	A	B	C	D	E	F
UVR-TOP 1	475	500	1120	350	450	800
UVR-TOP 2	555	500	1200	400	600	600
UVR-TOP 3	675	500	1294	400	700	700
UVR-TOP 4	750	500	1405	600	800	800
UVR-TOP 5	900	500	1530	600	900	900
UVR-TOP 6	1000	600	1780	700	1000	1000

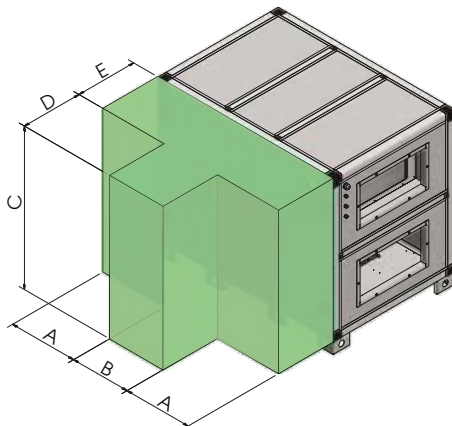

MODELLO	Dimensioni (mm)				
	A	B	C	D	E
UVR 1	422	500	923	350	450
UVR 2	495	500	1035	400	600
UVR 3	555	500	1294	400	700
UVR 4	600	500	1405	600	800
UVR 5	760	500	1530	600	900
UVR 6	900	600	1780	700	1000



UVR CONFIGURATIONS with pre and post

UVR size 1 and 2 (no PRE or POST)

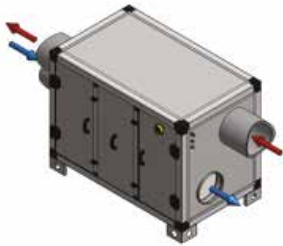

UVR size 1 and 2, PRE or POST electrical on the edge of the unit



UVR size 1 and 2, post H₂O hot (temperate)

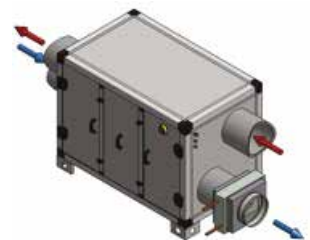

UVR size 1 and 2, post H₂O cold/hot

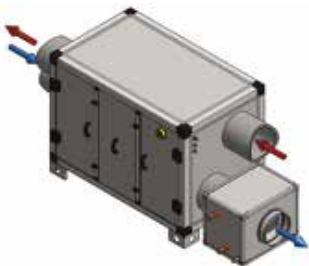

UVR size 3, 4, 5 and 6 (no PRE or POST)



UVR size 3, 4, 5 and 6, PRE or POST electrical, on the edge of the unit



UVR size 3, 4, 5 and 6, post H₂O hot (temperate)



UVR size 3, 4, 5 and 6, post H₂O cold/hot



UVR-TOP CONFIGURATIONS with pre and post

UVR-TOP size 1 and 2 (no PRE or POST)

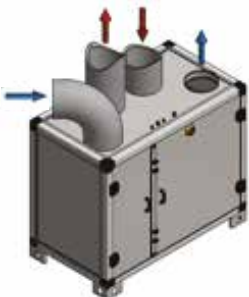

UVR-TOP size 1 and 2, PRE or POST electrical, on the edge of the unit

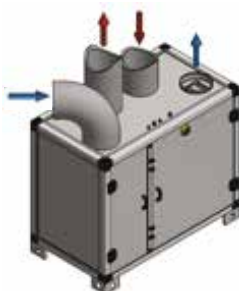

UVR-TOP size 1 and 2, post H₂O hot (temperate), on the edge of the unit

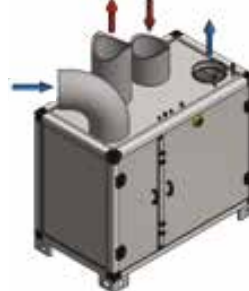

UVR-TOP size 1 and 2, post H₂O cold/hot

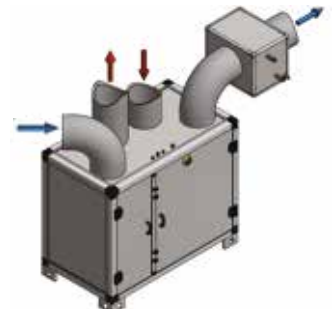

UVR-TOP size 3, 4, 5 and 6 (no PRE or POST)



UVR-TOP size 3, 4, 5 and 6, PRE or POST electrical, on the edge of the unit



UVR-TOP size 3, 4, 5 and 6, post H₂O hot (temperate) on the edge of the unit

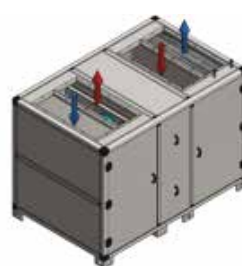

UVR-TOP size 3, 4, 5 and 6, post H₂O cold/hot

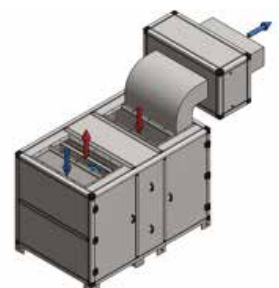



ADDITIONAL MODULES COILS

BA-AF Cold/hot water coil

MODEL	A	B	C	F	UVR				UVR-TOP			
					Hole	Weight	Note	Attacks	Hole	Weight	Note	Ø
1	560	400	430	3/8"	Ø 250	24	On duct	1"	Ø 250	24	On duct	1"
2	690	400	550	3/8"	Ø 315	40	On duct	1"	Ø 315	40	On duct	1"
3	1106	524	683	1/2"	600x308	39	Module	3/4"	700x208	46	On duct	3/4"
4	1356	574	738	1/2"	700x408	56	Module	1"	1000x208	67	On duct	1"
5	1481	604	801	1/2"	800x408	84	Module	1"	1000x308	101	On duct	1"
6	1731	714	926	1/2"	1000x508	109	Module	1 1/2"	1200x308	133	On duct	1 1/2"

BA-AF for UVR and UVR-TOP 1-2

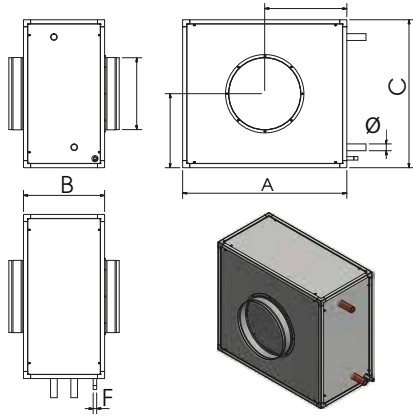

BA-AF for UVR and UVR-TOP 3-4-5-6

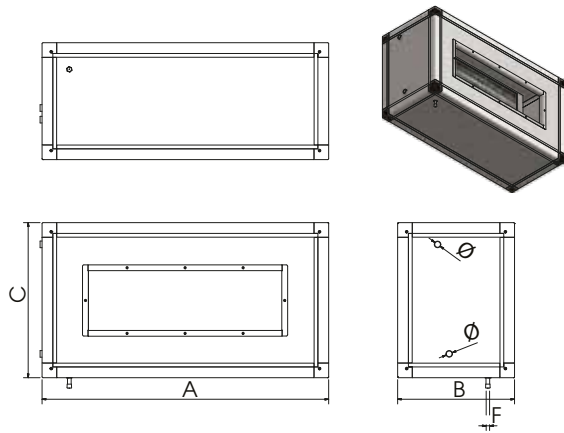

BA-AC Hot water coil

MODEL	A	B	C	UVR			
				Hole	Weight	Note	Ø
1	430	200	260	Ø 250	11	On duct	1/2"
2	490	200	320	Ø 315	15	On duct	3/4"
3	1106	524	683	600x308	31	Module	1/2"
4	1356	574	738	700x408	45	Module	3/4"
5	1481	604	801	800x408	67	Module	3/4"
6	1731	714	926	1000x508	89	Module	3/4"

In the UVR-TOP units the BA-AC are inside the machines
 In the UVR units the BA-AC units are outside to the machine

BA-AC for UVR 1-2

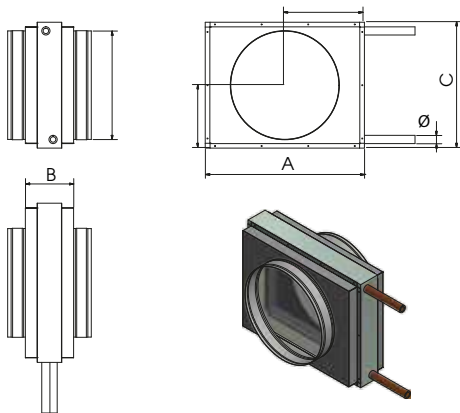

BA-AC for UVR 3-4-5-6

* In the BA-AC modules is not present the condensate drain

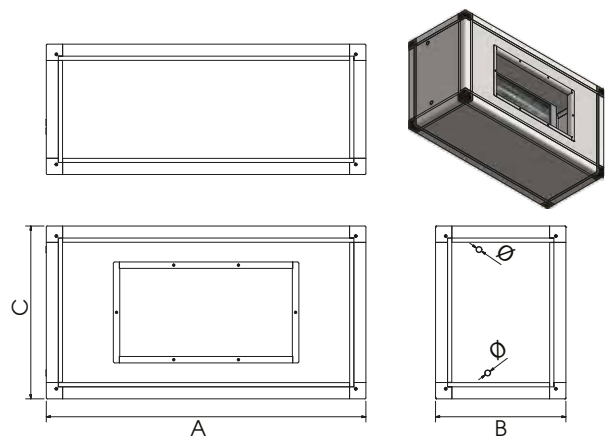



COIL UVR-TOP 1 Heating water coil (45°C/35°C)

Ø WATER ("gas)	N. ROWS	FIN PITCH (mm)	VOL.INT. (dm ³)	MATERIALS		
				TUBES	FINS	FRAME
1/2"	2	2.5	1	Cu	Al	Fe Zn

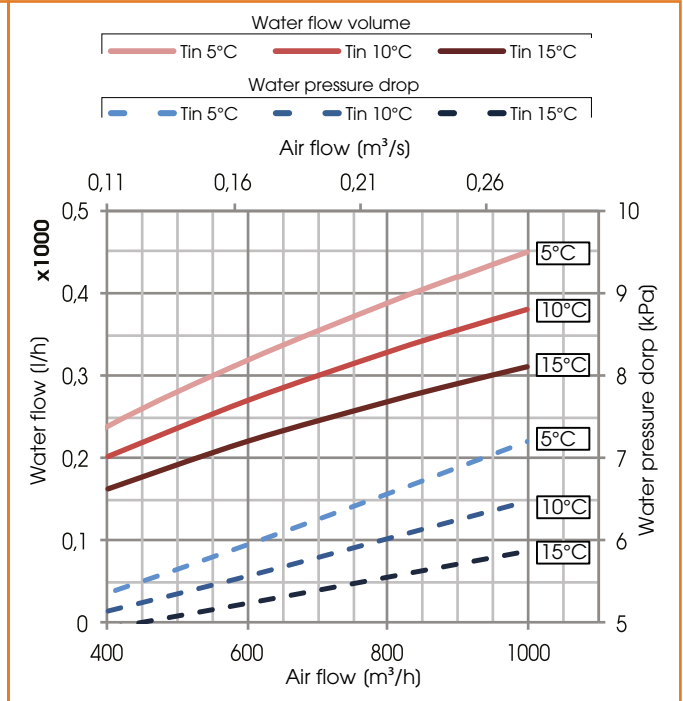
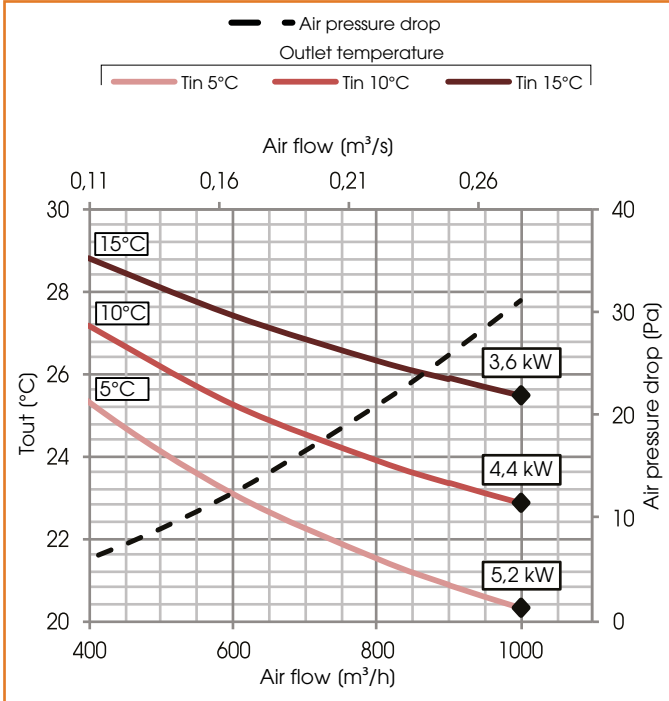

COILS UVR-TOP 2 Heating water coil (45°C/35°C)

Ø WATER ("gas)	N. ROWS	FIN PITCH (mm)	VOL.INT. (dm ³)	MATERIALS		
				TUBES	FINS	FRAME
1/2"	2	2.5	1	Cu	Al	Fe Zn

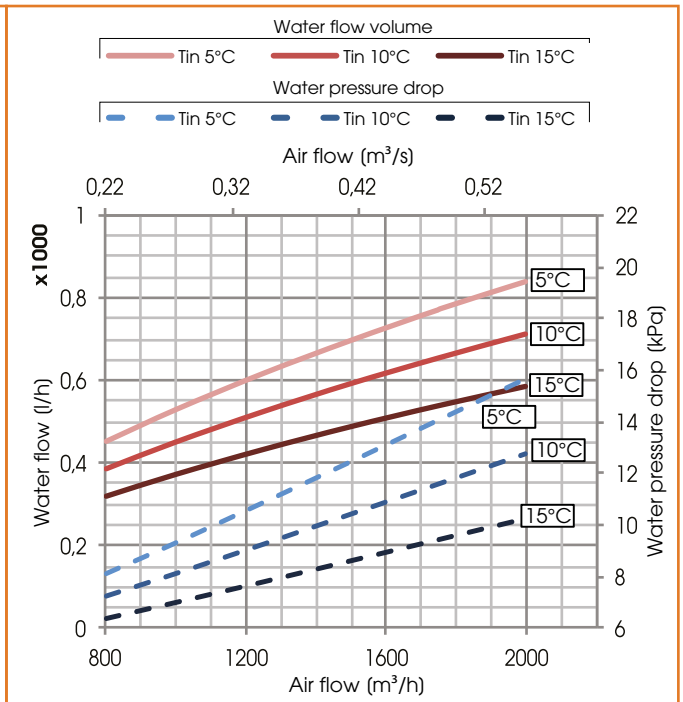
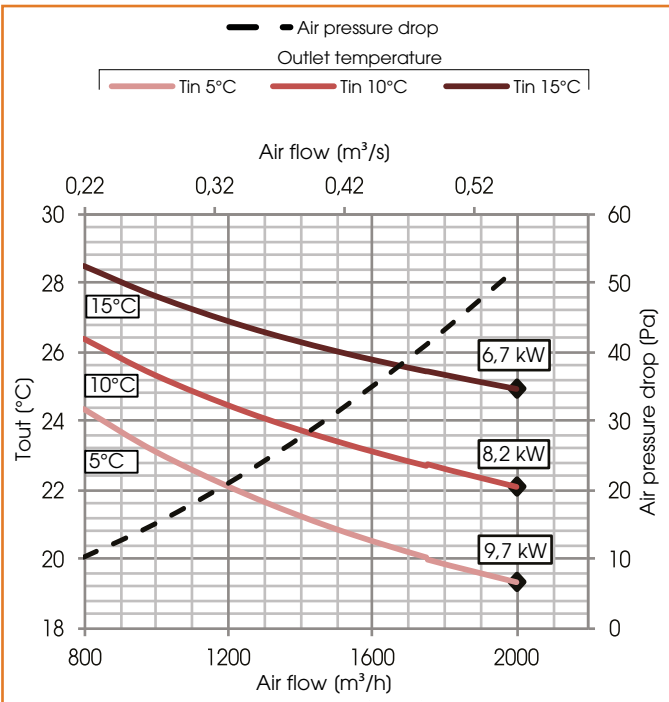



COILS UVR-TOP 3 Heating water coil (45°C/35°C)

Ø WATER ("gas)	N. ROWS	FIN PITCH (mm)	VOL.INT. (dm ³)	MATERIALS		
				TUBES	FINS	FRAME
1/2"	2	2,5	1	Cu	Al	Fe Zn

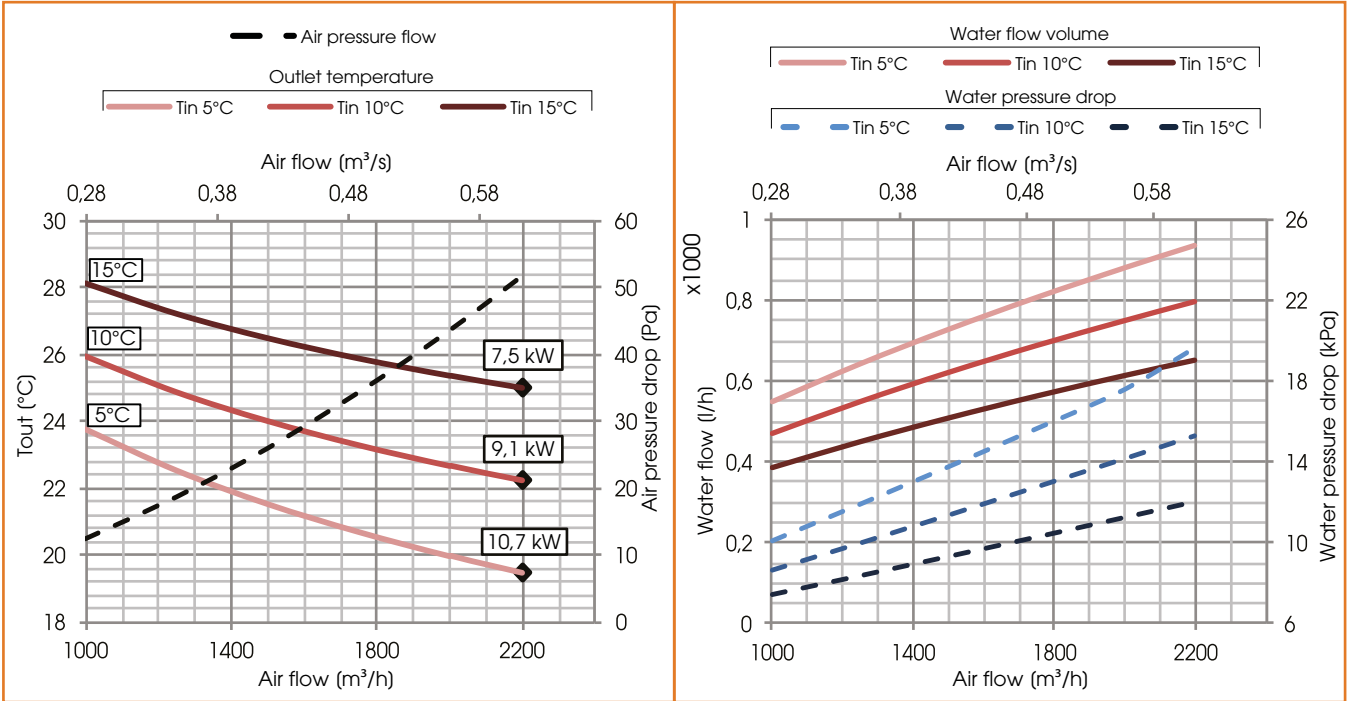

COILS UVR-TOP 4 Heating water coil (45°C/35°C)

Ø WATER ("gas)	N. ROWS	FIN PITCH (mm)	VOL.INT. (dm ³)	MATERIALS		
				TUBES	FINS	FRAME
1/2"	3	3,0	2	Cu	Al	Fe Zn

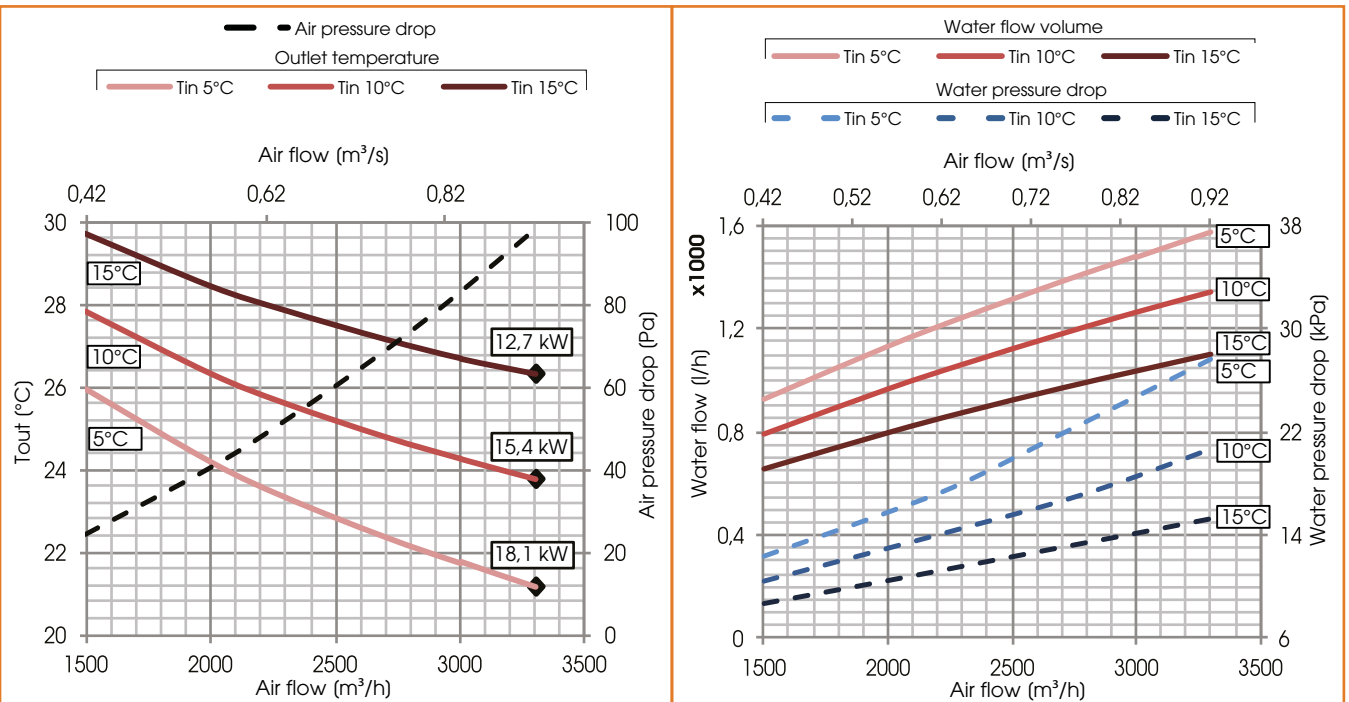



COILS UVR-TOP 5 Heating water coil (45°C/35°C)

				MATERIALS		
Ø WATER (”gas)	N. ROWS	FIN PITCH (mm)	VOL.INT. (dm ³)	TUBES	FINS	FRAME
3/4”	4	3,0	4	Cu	Al	Fe Zn

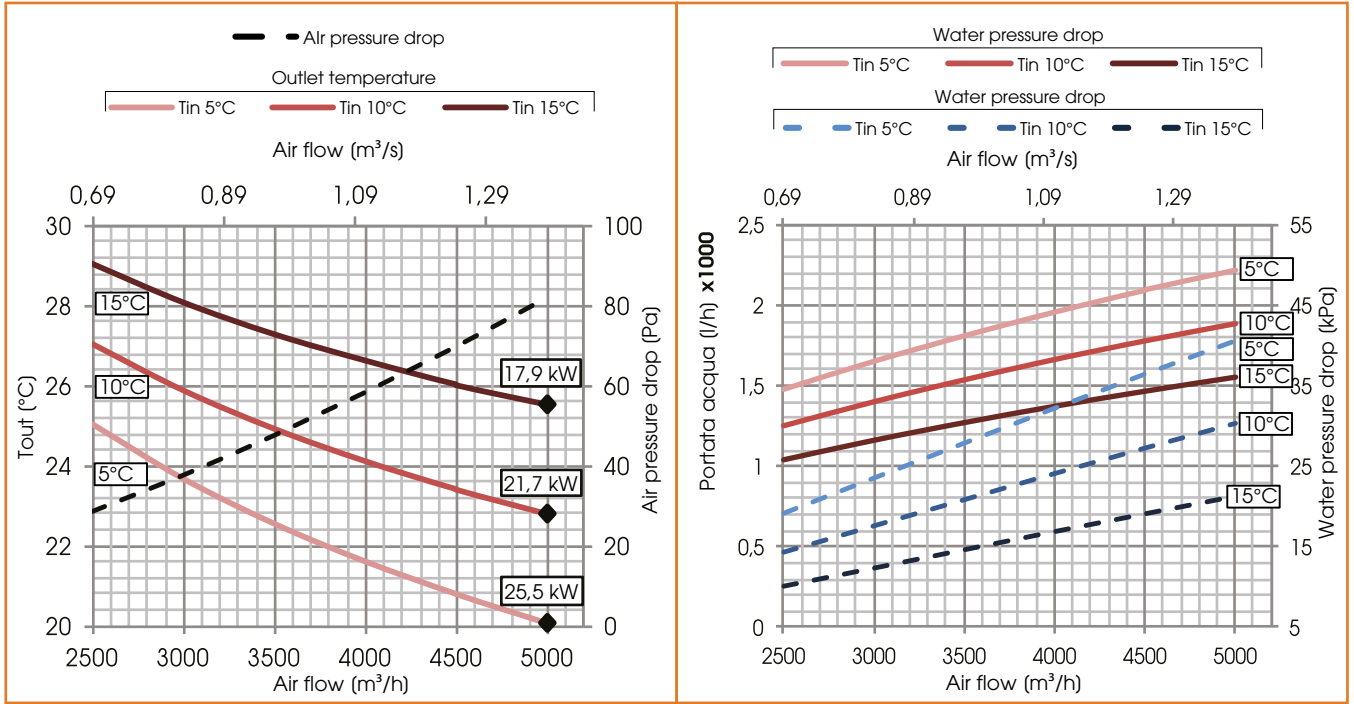

COILS UVR-TOP 6 Heating water coil (45°C/35°C)

				MATERIALS		
Ø WATER (”gas)	N. ROWS	FIN PITCH (mm)	VOL.INT. (dm ³)	TUBES	FINS	FRAME
1”	3	3,0	5	Cu	Al	Fe Zn

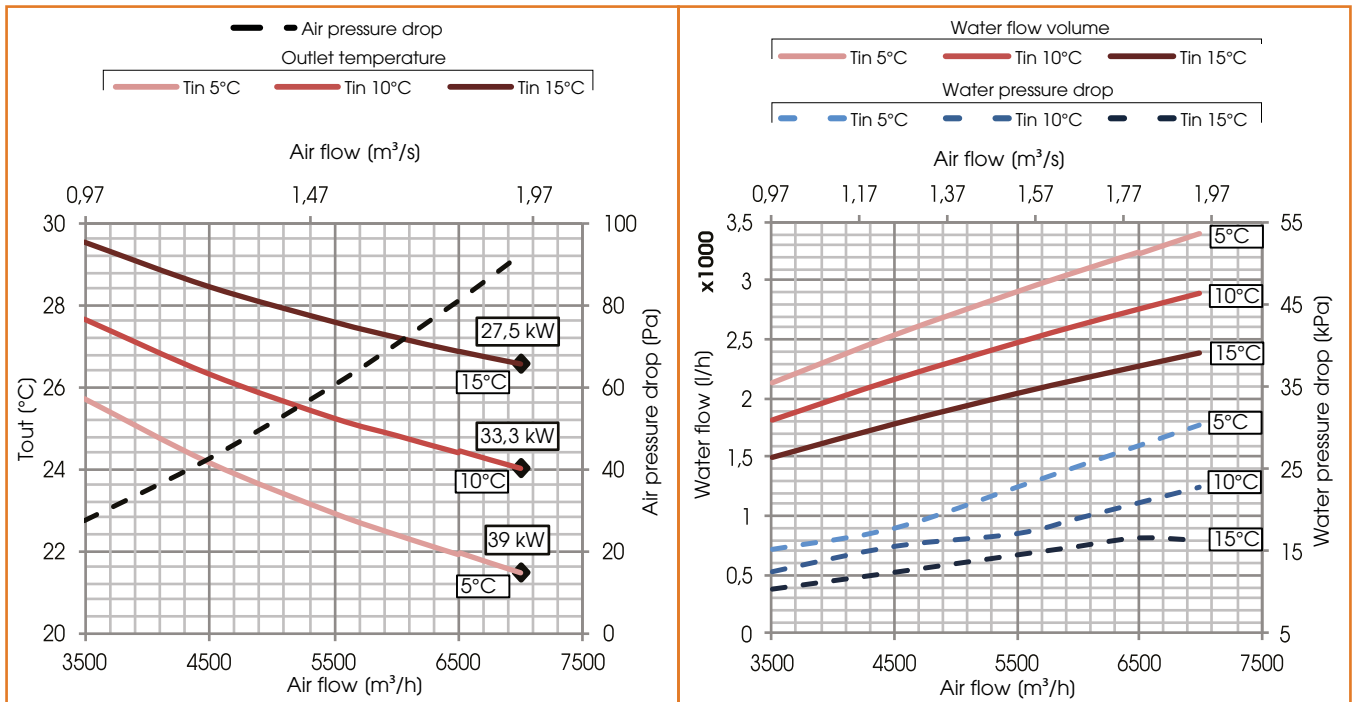



COILS UVR 1

Heating water coil (45°C/35°C)

Ø WATER (”gas)	N. ROWS	FIN PITCH (mm)	VOL.INT. (dm ³)	MATERIALS		
				TUBES	FINS	FRAME
1/2”	2	2.5	2	Cu	Al	Fe Zn

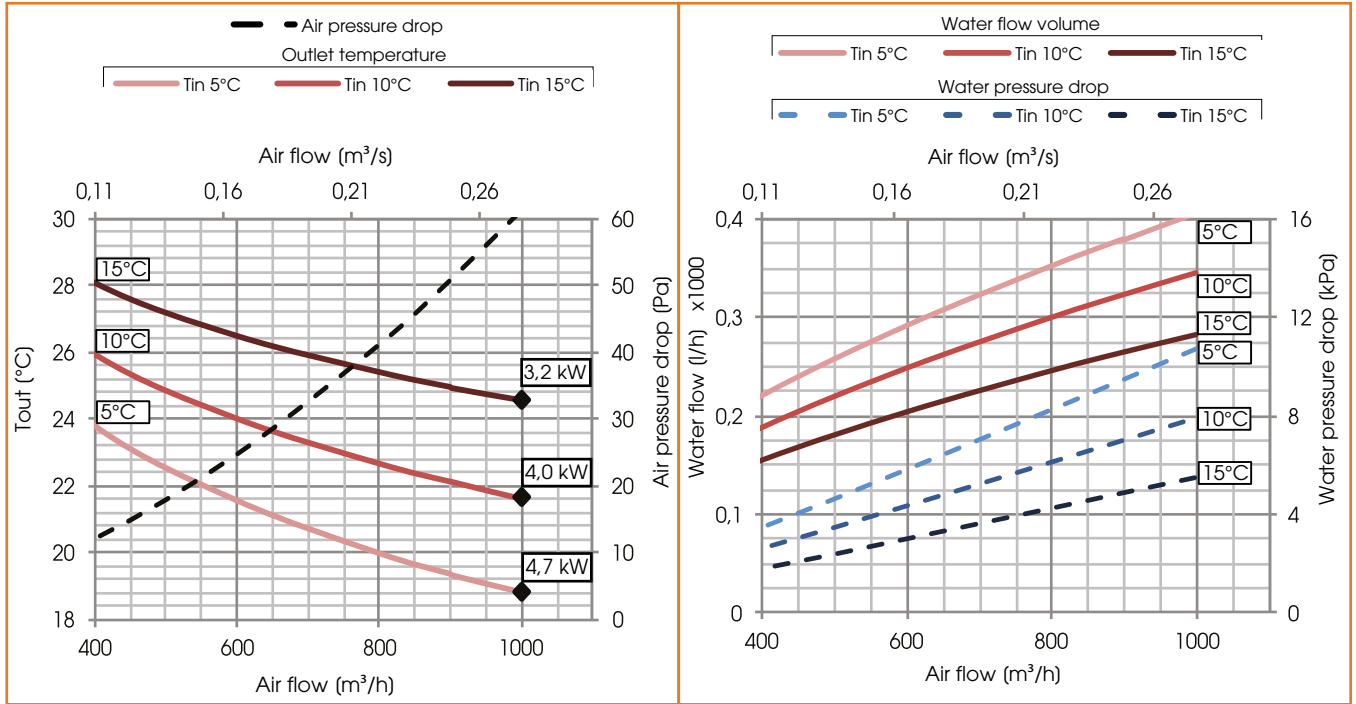

COILS UVR 2

Heating water coil (45°C/35°C)

Ø WATER (”gas)	N. ROWS	FIN PITCH (mm)	VOL.INT. (dm ³)	MATERIALS		
				TUBES	FINS	FRAME
3/4”	2	2.5	3	Cu	Al	Fe Zn

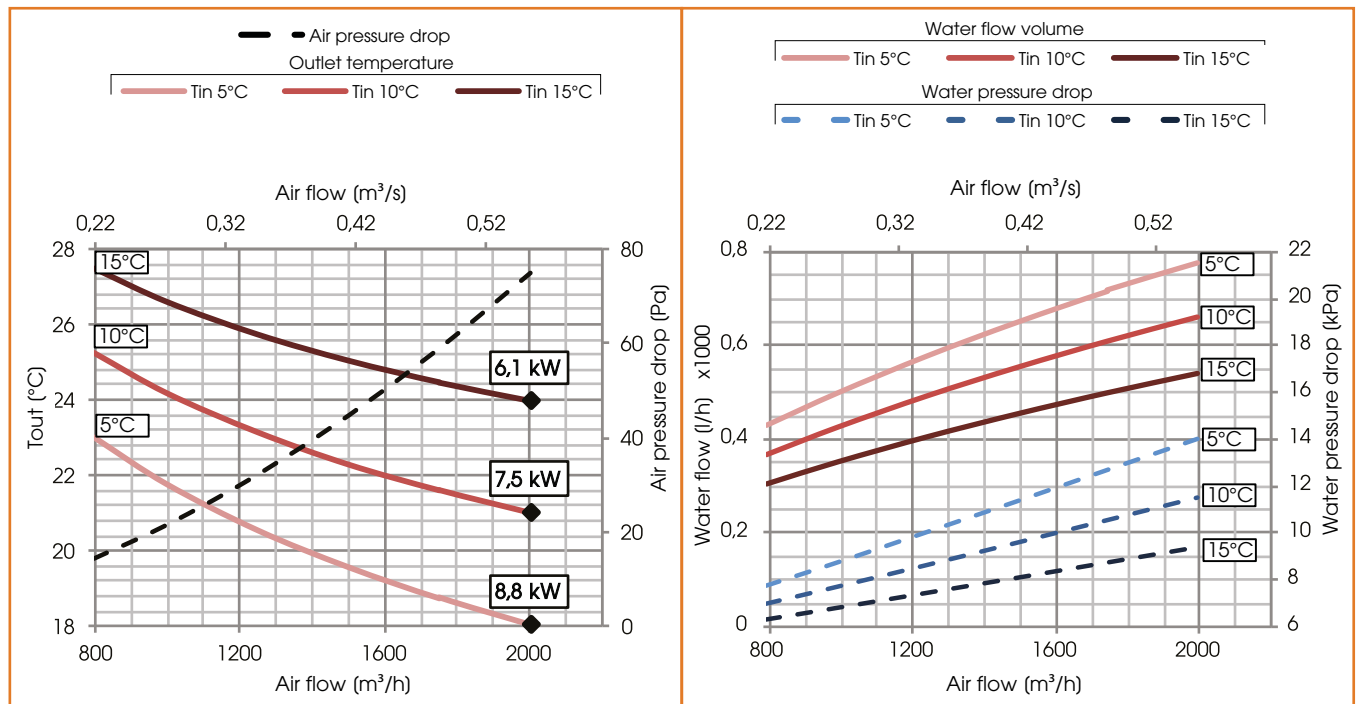



COILS UVR 3 Heating water coil (45°C/35°C)

Ø WATER ("gas)	N. ROWS	FIN PITCH (mm)	VOL.INT. (dm ³)	MATERIALS		
				TUBES	FINS	FRAME
1/2"	2	2.5	2	Cu	Al	Fe Zn

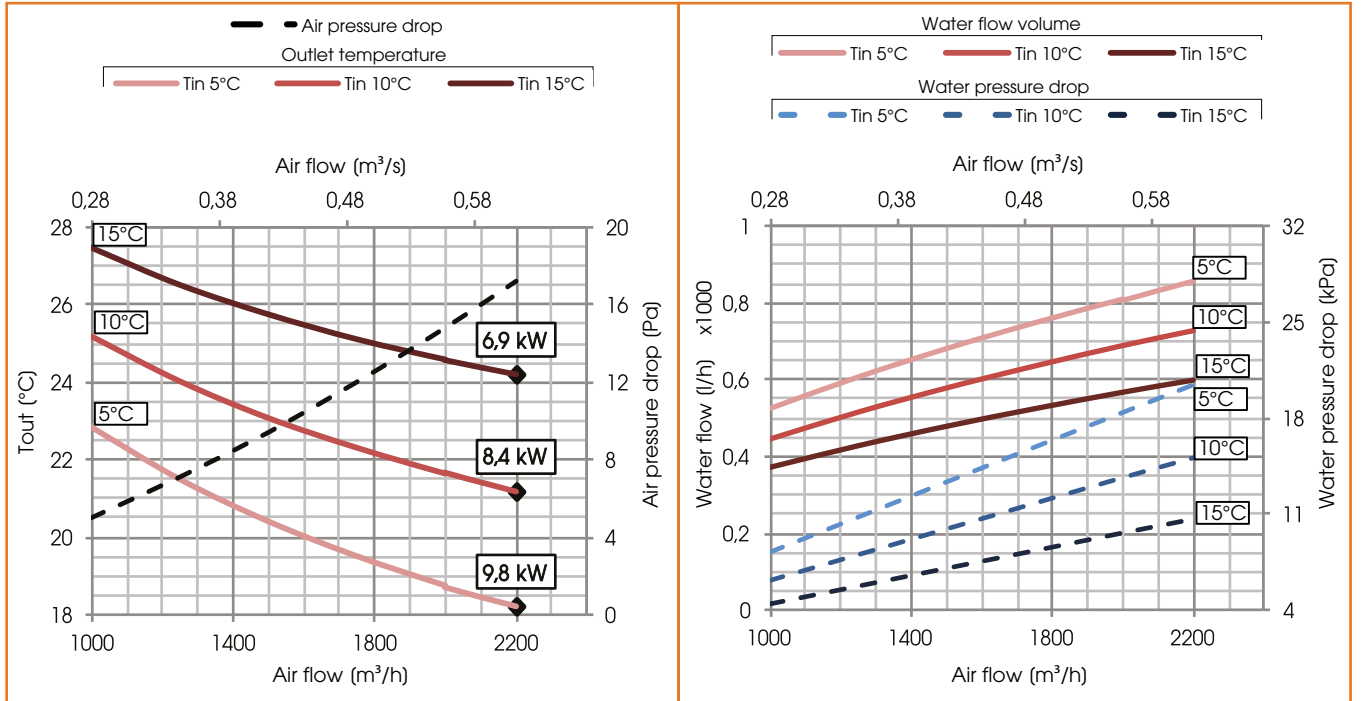

COILS UVR 4 Heating water coil (45°C/35°C)

Ø WATER ("gas)	N. ROWS	FIN PITCH (mm)	VOL.INT. (dm ³)	MATERIALS		
				TUBES	FINS	FRAME
3/4"	2	2.5	3	Cu	Al	Fe Zn

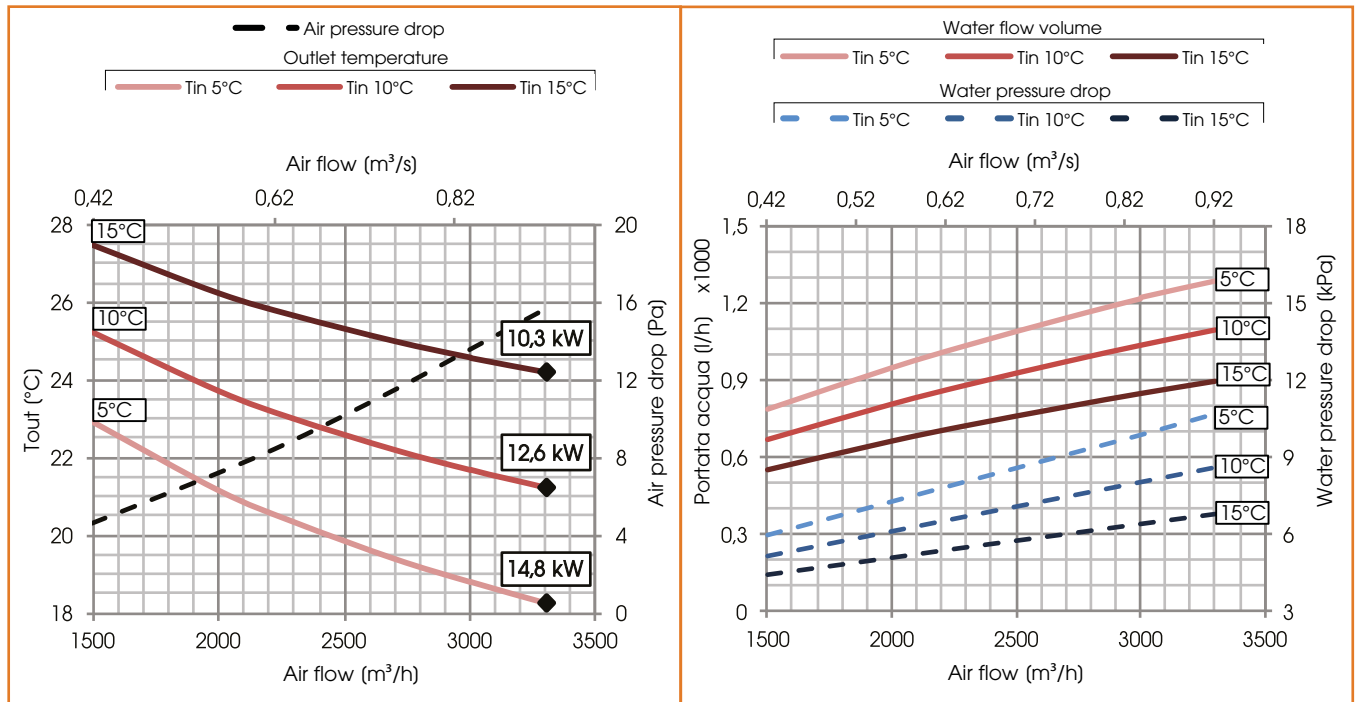



BATTERIE UVR 5 Heating water coil (45°C/35°C)

				MATERIALS		
Ø WATER ("gas)	N. ROWS	FIN PITCH (mm)	VOL.INT. (dm ³)	TUBES	FINS	FRAME
3/4"	2	2,5	4	Cu	Al	Fe Zn

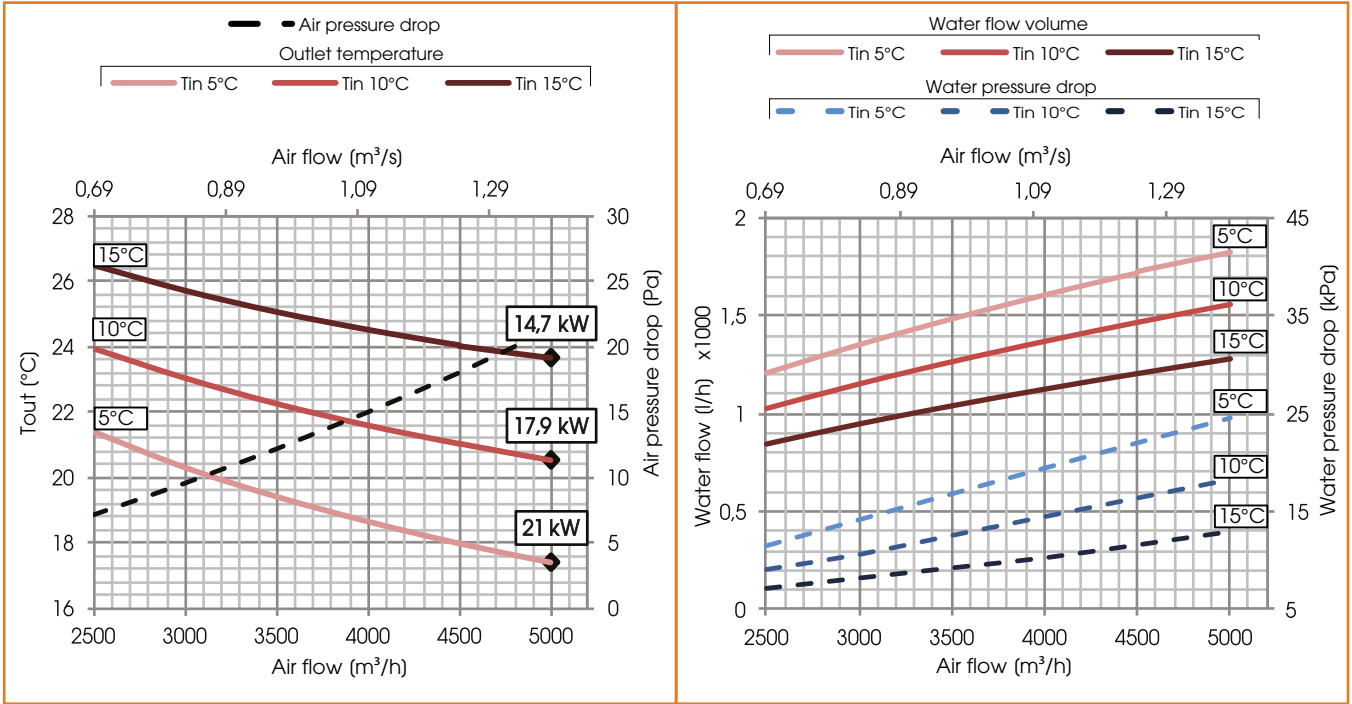

COILS UVR 6 Heating water coil (45°C/35°C)

				MATERIALS		
Ø WATER ("gas)	N. ROWS	FIN PITCH (mm)	VOL.INT. (dm ³)	TUBES	FINS	FRAME
3/4"	2	3,5	6	Cu	Al	Fe Zn

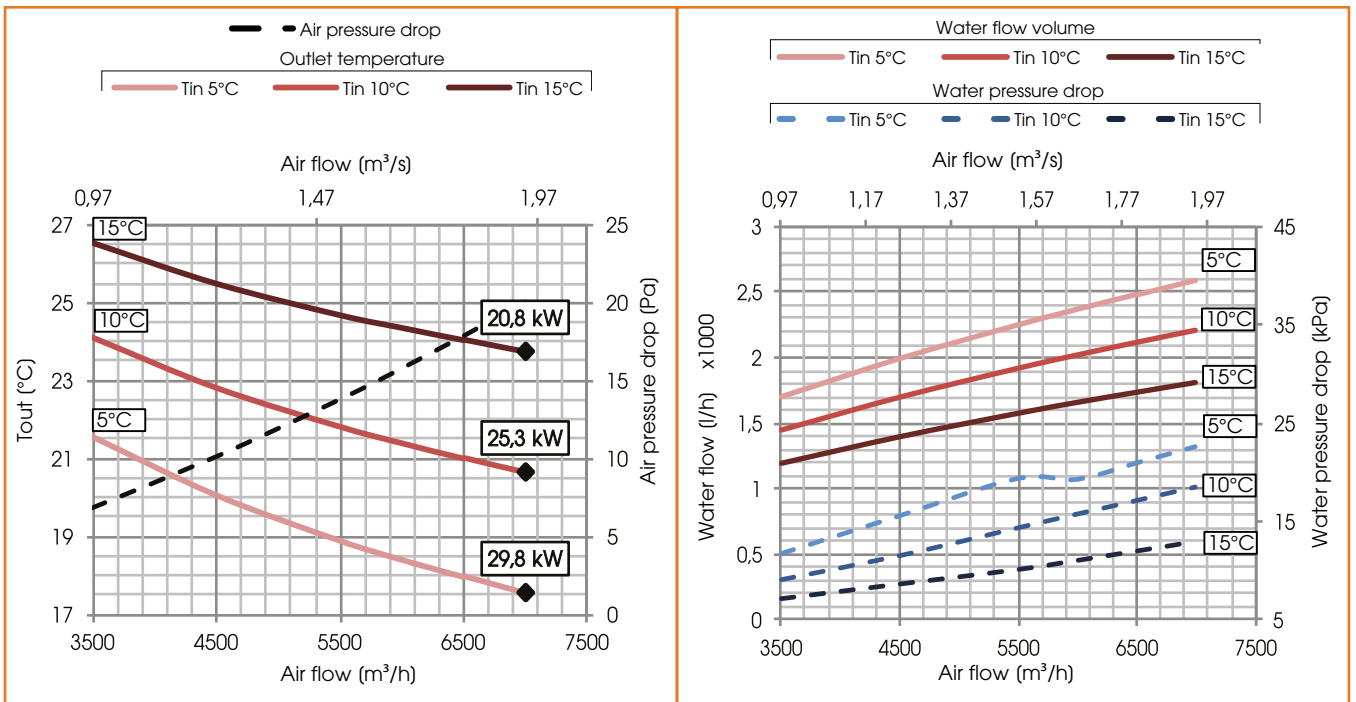



COILS UVR & UVR-TOP 1 Cooling water coil (7°C/12°C)

Ø WATER ("gas)	N. ROWS	FIN PITCH (mm)	VOL.INT. (dm³)	MATERIALS		
				TUBES	FINS	FRAME
1"	4	2,5	3	Cu	Al	Fe Zn

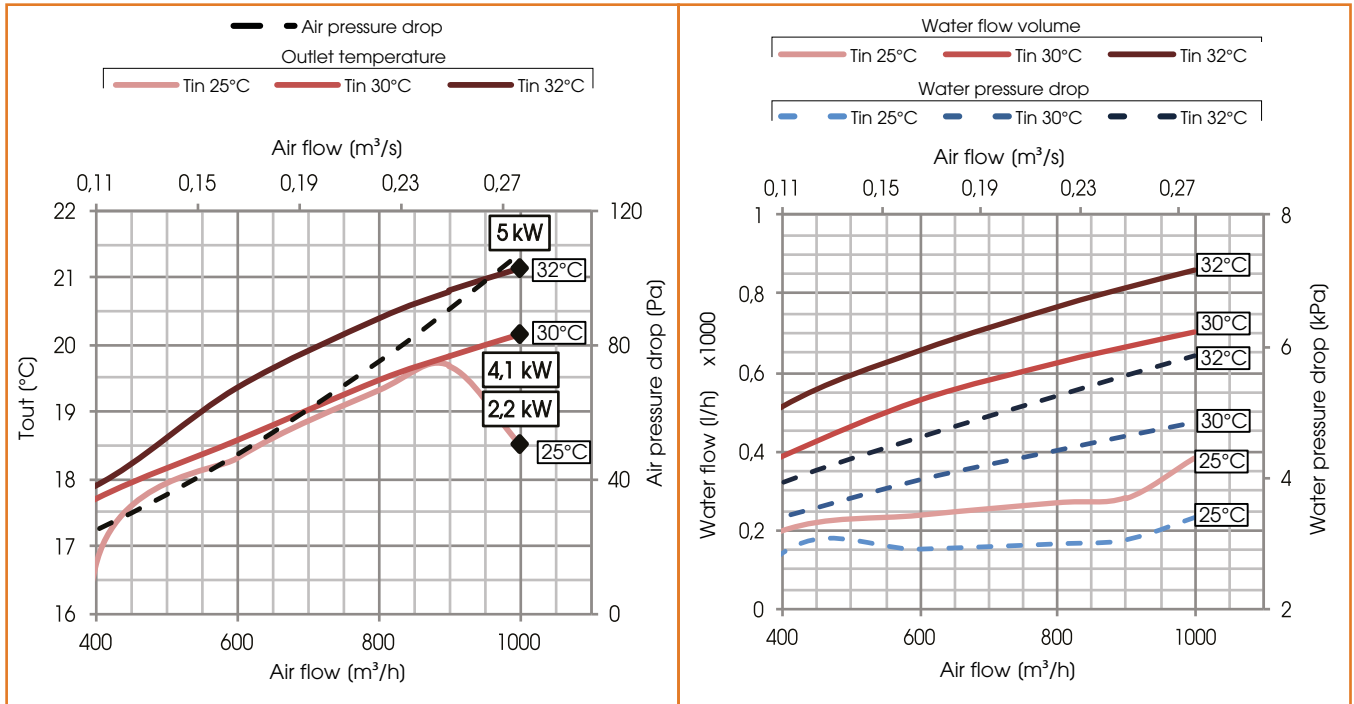

COILS UVR & UVR-TOP 2 Cooling water coil (7°C/12°C)

Ø WATER ("gas)	N. ROWS	FIN PITCH (mm)	VOL.INT. (dm³)	MATERIALS		
				TUBES	FINS	FRAME
1"	4	2,5	5	Cu	Al	Fe Zn

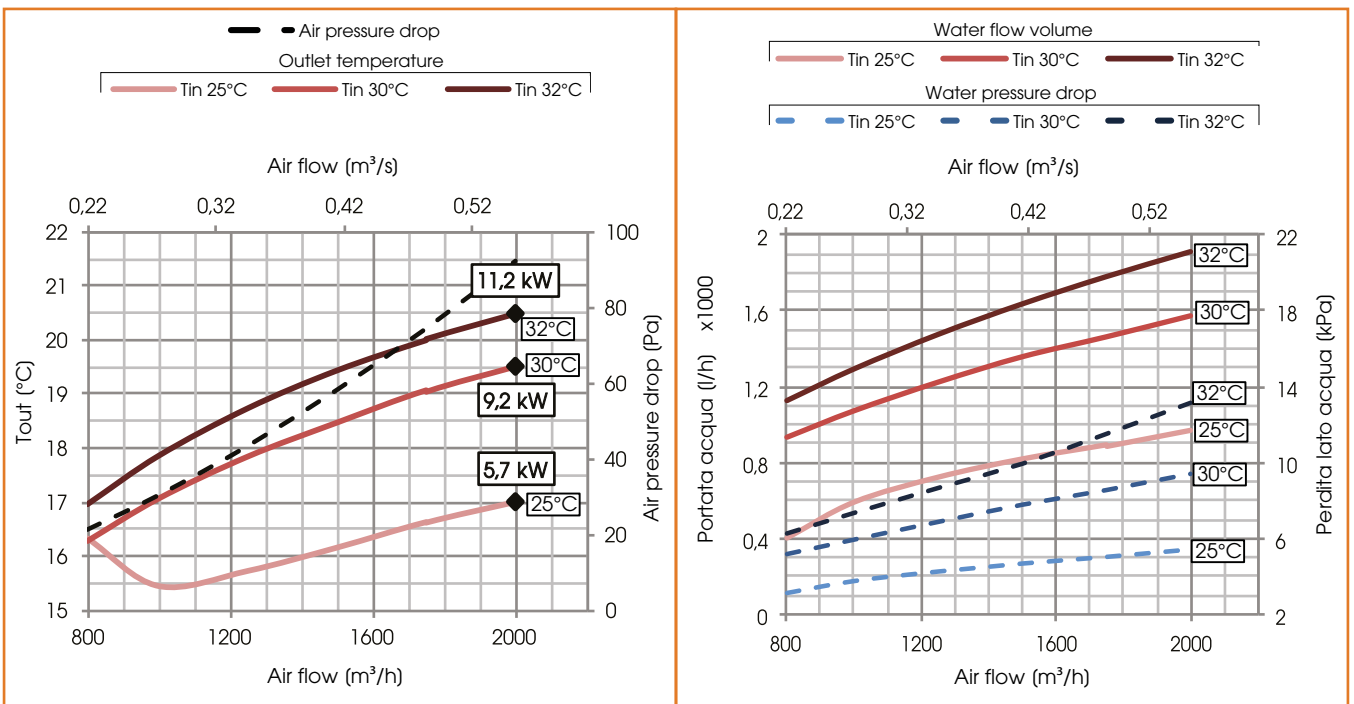



COILS UVR & UVR-TOP 3 Cooling water coil (7°C/12°C)

Ø WATER ("gas)	N. ROWS	FIN PITCH (mm)	VOL.INT. (dm ³)	MATERIALS		
				TUBES	FINS	FRAME
3/4"	4	2,5	6	Cu	Al	Fe Zn

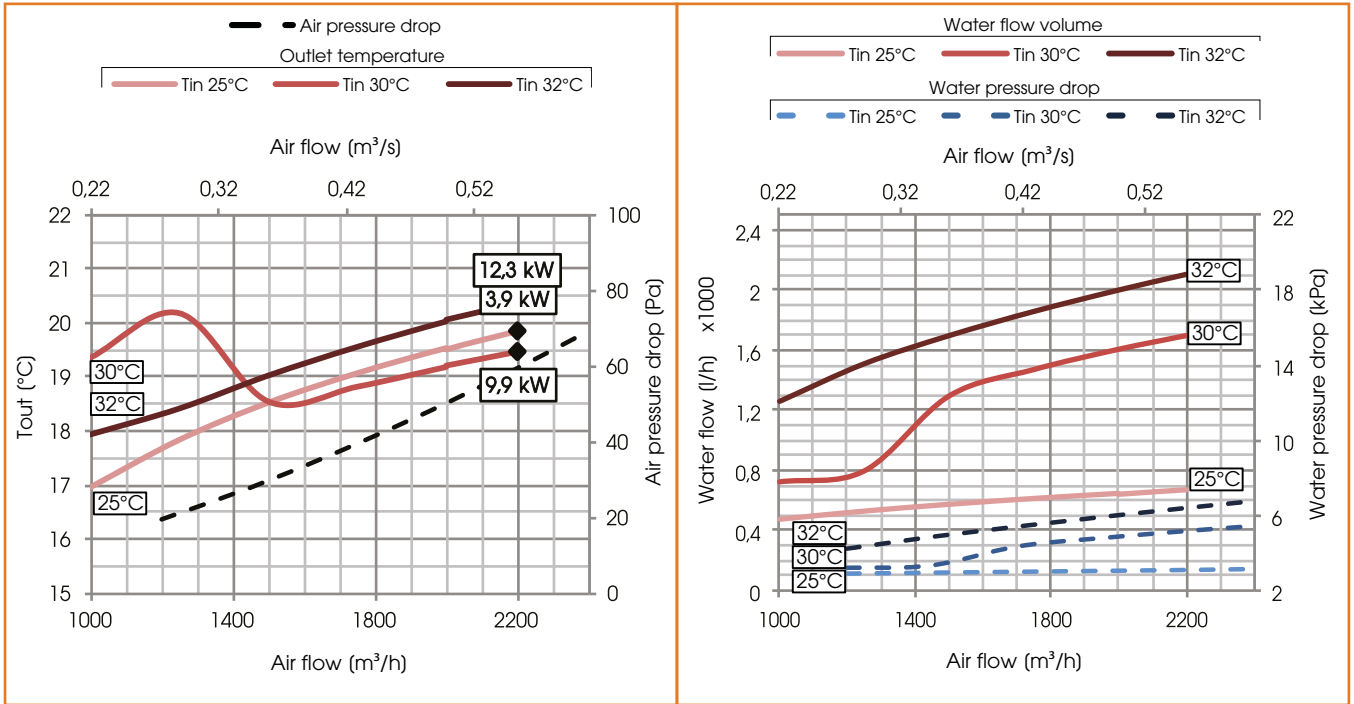

COILS UVR & UVR-TOP 4 Cooling water coil (7°C/12°C)

Ø WATER ("gas)	N. ROWS	FIN PITCH (mm)	VOL.INT. (dm ³)	MATERIALS		
				TUBES	FINS	FRAME
1"	3	2,5	7	Cu	Al	Fe Zn

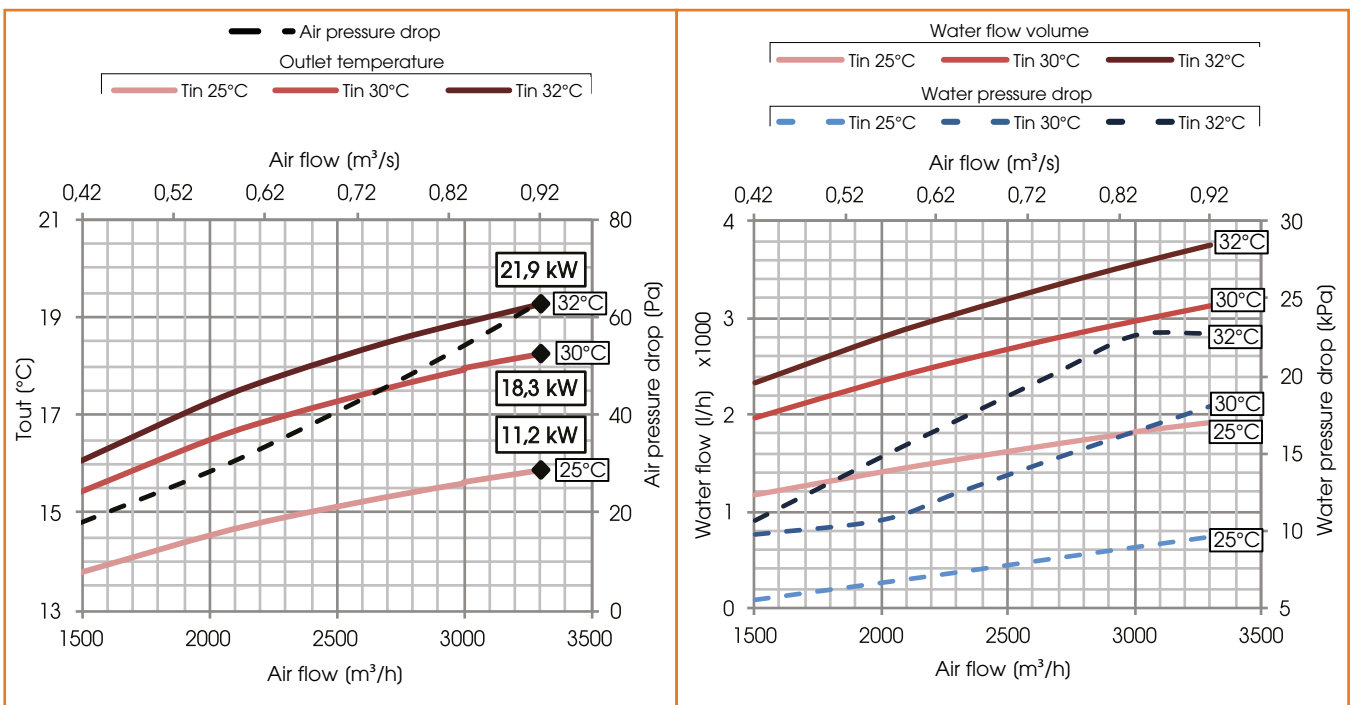



COILS UVR & UVR-TOP 5 Cooling water coil (7°C/12°C)

Ø WATER ("gas)	N. ROWS	FIN PITCH (mm)	VOL.INT. (dm ³)	MATERIALS		
				TUBES	FINS	FRAME
1"	3	2,5	8	Cu	Al	Fe Zn

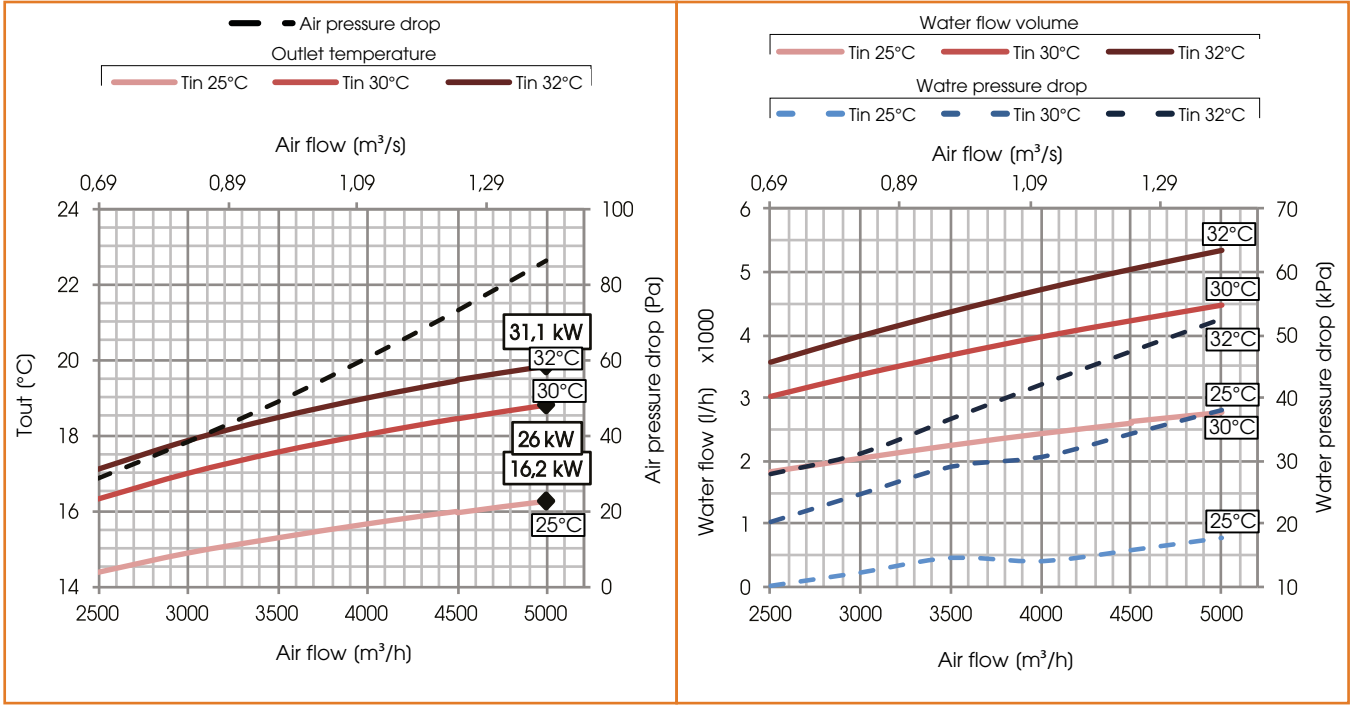

COILS UVR & UVR-TOP 6 Cooling water coil (7°C/12°C)

Ø WATER ("gas)	N. ROWS	FIN PITCH (mm)	VOL.INT. (dm ³)	MATERIALS		
				TUBES	FINS	FRAME
1 1/2"	4	3,0	12	Cu	Al	Fe Zn

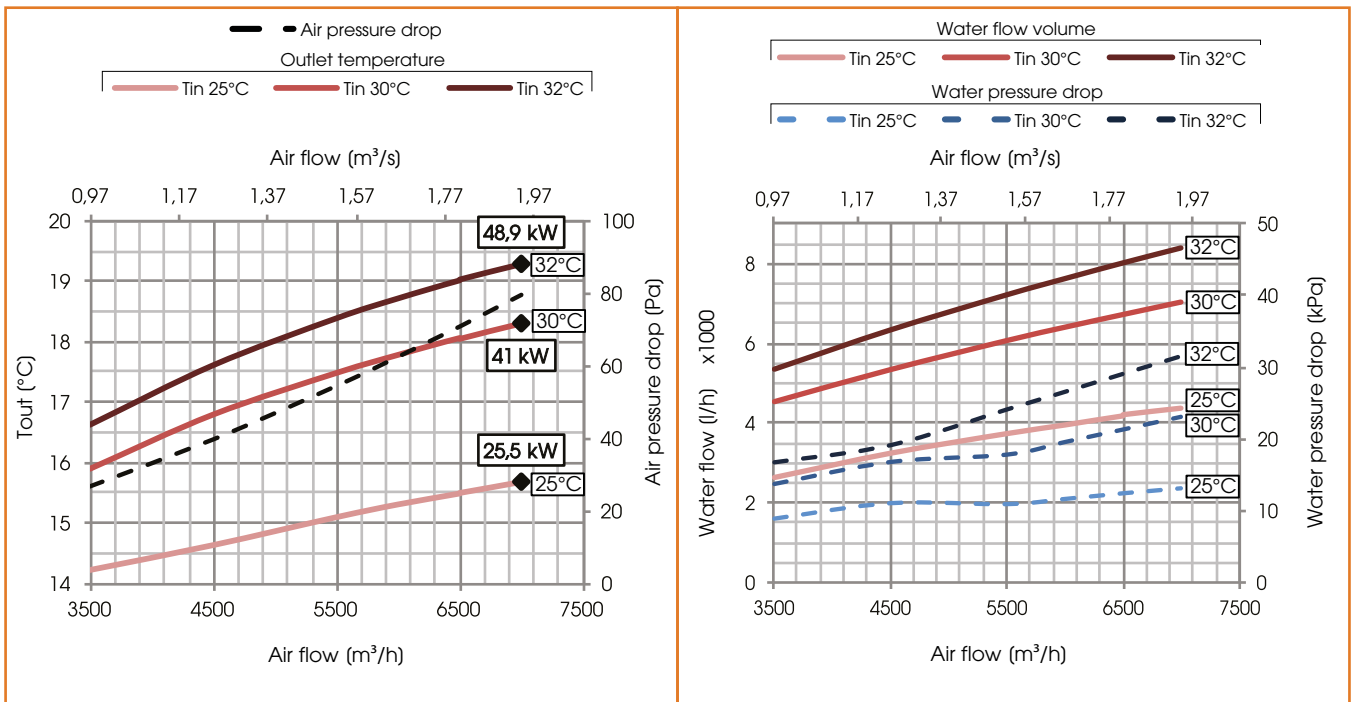



Electrical heater

POST and PRE ELECTRICAL HEATER TECHNICAL DATA				
Unit	Supply	Power (kW)	Current (A)	N. stages
UVR & UVR-TOP 1	230V, 50Hz, 1F	4	17,4	1
UVR & UVR-TOP 2	230V, 50Hz, 1F	6	26,1	1
UVR & UVR-TOP 3	400V, 50Hz, 3F	8	11,6	1
UVR & UVR-TOP 4	400V, 50Hz, 3F	12	17,4	1
UVR & UVR-TOP 5	400V, 50Hz, 3F	16	23,2	1
UVR & UVR-TOP 6	400V, 50Hz, 3F	24	34,8	1

N.B. - for other batteries PRE or POST treatment see the Techno-list of ACCESSORIES

A	Manufacturer's name	UTEK srl											
B	Manufacturer's model identifier	UVR & UVR-TOP 1		UVR & UVR-TOP 2		UVR & UVR-TOP 3		UVR & UVR-TOP 4		UVR & UVR-TOP 5		UVR & UVR-TOP 6	
C	Declared typology	UVNR / UVB		UVNR / UVB		UVNR / UVB		UVNR / UVB		UVNR / UVB		UVNR / UVB	
D	Type of drive installed	Variable speed drive		Variable speed drive		Variable speed drive		Variable speed drive		Variable speed drive		Variable speed drive	
E	Type of HRS	other		other		other		other		other		other	
F	Thermal efficiency of heat recovery (%)	81,2	78,2	81,2	82,0	81,2	82,0	81,2	82,0	81,2	82,0	81,2	82,0
G	Nominal NRUV flow rate (m³/s)	0,27	0,57	0,61	0,82	0,61	0,82	0,61	0,82	0,61	0,82	0,61	0,82
H	Effective electric power input (kW)	0,35	0,95	0,92	1,48	0,92	1,48	0,92	1,48	0,92	1,48	0,92	1,48
I	SFPint (W/(m³/s))	804	1101	908	1205	908	1205	908	1205	908	1205	908	1205
J	Face velocity at design flow rate (m/s)	1,09	1,54	1,16	1,16	1,16	1,16	1,16	1,16	1,16	1,16	1,16	1,16
K	Nominal external pressure (Pa)	100	100	100	100	100	100	100	100	100	100	100	100
L	Internal pressure drop of ventilation components (Pa)	434	525	392	518	392	518	392	518	392	518	392	518
M	Optional: internal pressure drop of non-ventilation components	-	-	-	-	-	-	-	-	-	-	-	-
N	Static efficiency of fans used in accordance with Regulation (EU) No 327/2011 (%)	53,8	48,8	43,3	49,1	43,3	49,1	43,3	49,1	43,3	49,1	43,3	49,1
O	Declared maximum external leakage rate of the casing of ventilation units (%)	4,3	2,0	2,2	2,1	2,2	2,1	2,2	2,1	2,2	2,1	2,2	2,1
P	Declared maximum internal leakage rate of bidirectional ventilation units or carry over (for regenerative heat exchangers only) (%)	-	-	-	-	-	-	-	-	-	-	-	-
Q	Energy performance, preferably energy classification, of the filters (declared information about the calculated annual energy consumption)	ePM1 70% (F7) ePM10 50% (M5)	ePM1 70% (F7) ePM10 50% (M5)	ePM1 70% (F7) ePM10 50% (M5)	ePM1 70% (F7) ePM10 50% (M5)	ePM1 70% (F7) ePM10 50% (M5)	ePM1 70% (F7) ePM10 50% (M5)	ePM1 70% (F7) ePM10 50% (M5)	ePM1 70% (F7) ePM10 50% (M5)	ePM1 70% (F7) ePM10 50% (M5)	ePM1 70% (F7) ePM10 50% (M5)	ePM1 70% (F7) ePM10 50% (M5)	ePM1 70% (F7) ePM10 50% (M5)
R	Position and description of visual filter warning for RVUs intended for use with filters, including text pointing out the importance of regular filter changes for performance and energy efficiency of the unit	Filter warning is signaled on the display of the control system: the flashing writing "DirtyFilters" will appear. "To preserve the energy efficiency of the NRUV, it's recommended to replace the filters when signaled." Positioned near the filters inspection											
R	Casing sound power level (LWA) (dB)	66	71	72	77	72	77	72	77	72	77	72	77
S	Internet address for pre-/dis-assembly instructions	utek-air.it											

UTEK reserves the right to at any time the necessary changes to improve products without prior notice .

Dear Customer

Thanks for your attention to the product UTEK , designed and manufactured to ensure the real values to the User : Quality, Safety and Savings on working.



Made in Italy

**AZIENDA CON SISTEMA
DI GESTIONE QUALITÀ
CERTIFICATO DA DNV GL
ISO 9001**

**AZIENDA CON
SISTEMA DI GESTIONE
AMBIENTALE CERTIFICATO
DA DNV
ISO 14001**



the Dealer
UVR & UVR-TOP_2018_2_EN



HEAT RECOVERY VENTILATION UNITS for COMMERCIAL and INDUSTRIAL BUILDINGS