



indoor air quality and energy saving

TECHNICAL DATA



CRHE-TOP



VENTILATION UNIT WITH HEAT RECOVERY FOR COMMERCIAL AND INDUSTRIAL BUILDINGS



CRHE-TOP

Non-residential dual flow ventilation unit with high efficiency heat recovery. All sizes are also available in the version with enthalpy exchanger.

PERFORMANCE

Equipped with an aluminum counter-current heat exchanger (Eurovent certified) and EC backward-curved electronic fans. The standard automatic total bypass makes it possible to take advantage of favorable conditions outside the building for free cooling (or free heating) in automatic mode.

STRUCTURE

CRHE-TOP is made with a frame in extruded aluminum profiles and sandwich panels, 25 mm thick, insulated in polyurethane foam. The panels and internal components are made of magnesium zinc, a material that ensures high resistance to corrosion and oxidation. Frontal panels makes it easy to access the filters ePM1 55% (F7) for fresh air flow and Coarse 65% (G4) or ePM10 50% (M5) for fresh air flow extraction). The CRHE-TOP is designed to be installed inside or outside buildings (if installed outside, it must be installed under cover). Available in 6 sizes, it can be equipped with air post-treatment systems (inside the unit) such as: hot water coil and electric heater. The pre-heating resistance is inside the machine between the filter and the exchanger.

CONTROLS

CRHE-TOP is supplied complete with electrical panel and control system; the version equipped with EVO-PH control and the version equipped with EVOD-PH-IP control are available, designed for complete integration into home automation systems (Modbus protocol with Ethernet connection or, on request, with the addition of the RS485 connection).

The new version of our control systems allows the passage from one control system to another with extreme ease and speed, even after installation with only the replacement of the remote panel.

The EVO-PH control has a color backlit touch screen interface which allows an intuitive view of the operating status of the machine; it allows precise adjustment of the fan speed and has a weekly time schedule for automatic management of the fans. EVO-PH can be controlled by an external switch to activate the booster function; it can automatically adjust the air flow if connected to an air quality probe; it can manage any air post-treatment accessories, it automatically manages the bypass and prevents frosting of the heat exchanger by managing the speed of the fans or, if installed, an electric preheating resistance (optional accessory external to the machine); signals to the user the need to replace the filters (the clogging status of the filters is monitored by a pair of standard differential pressure switches) or the onset of an anomaly, indicating its origin. With the addition of optional accessories (Kit COP and Kit CAV installed in the duct) it is possible to manage the ventilation machine in constant pressure or constant flow rate mode.

The EVOD-PH-IP controller has the same features as the EVO-PH version with the addition of the Modbus communication protocol which allows full control of the machine by the home automation system supervision software. The implemented webserver allows you to interact with the machine even with an internet browser of a device connected (even remotely) to the home automation network in which the machine itself is inserted. For a more complete view of the characteristics of the control systems, please refer to the respective manuals.

ACCESSORIES

CRHE-TOP can be equipped with other accessories such as:

- . R.H., CO2 or CO2/VOC probe
- . kit for operation at constant pressure or flow rate

For a more complete view of the characteristics of the control systems, please refer to the respective manuals.

CRHE-TOP

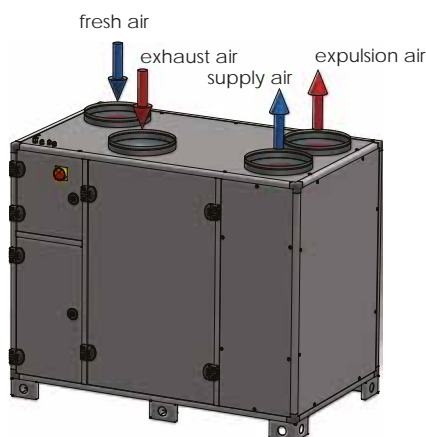

CRHE-TOP "MIRRORED"

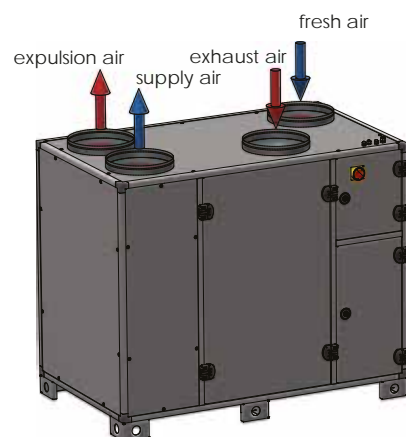

Counterflow heat exchanger made of aluminum and enthalpic version manufactured by RECUTECH. RECUTECH participates in the Eurovent Certification Program



PERFORMANCE (UNI EN 13141-7)

The unit must be ducted properly: UTEK authorizes the use only according to its performance diagram shown into this catalogue
The declared performances are with CLEAN filters, and guaranteed ONLY with the original filters UTEK low pressure drop.

CRHE-TOP 1

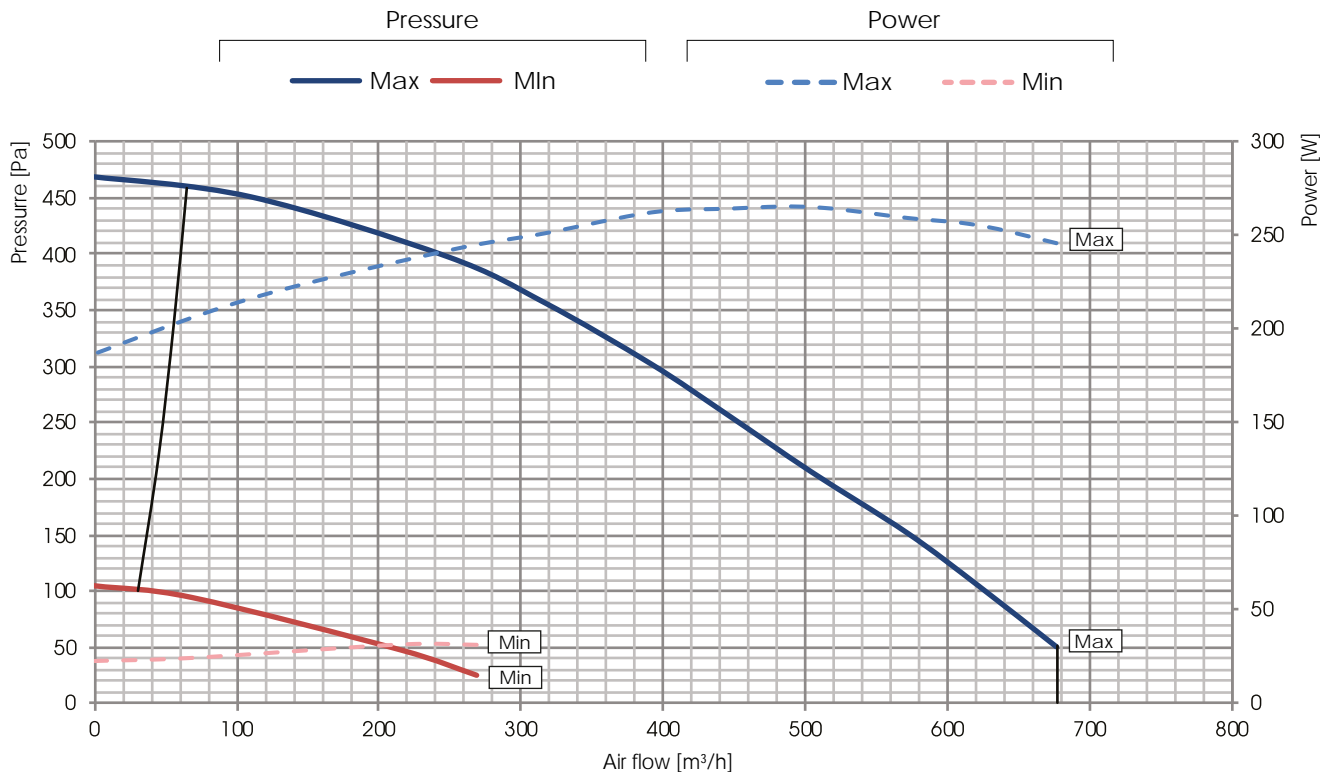

CRHE-TOP 2

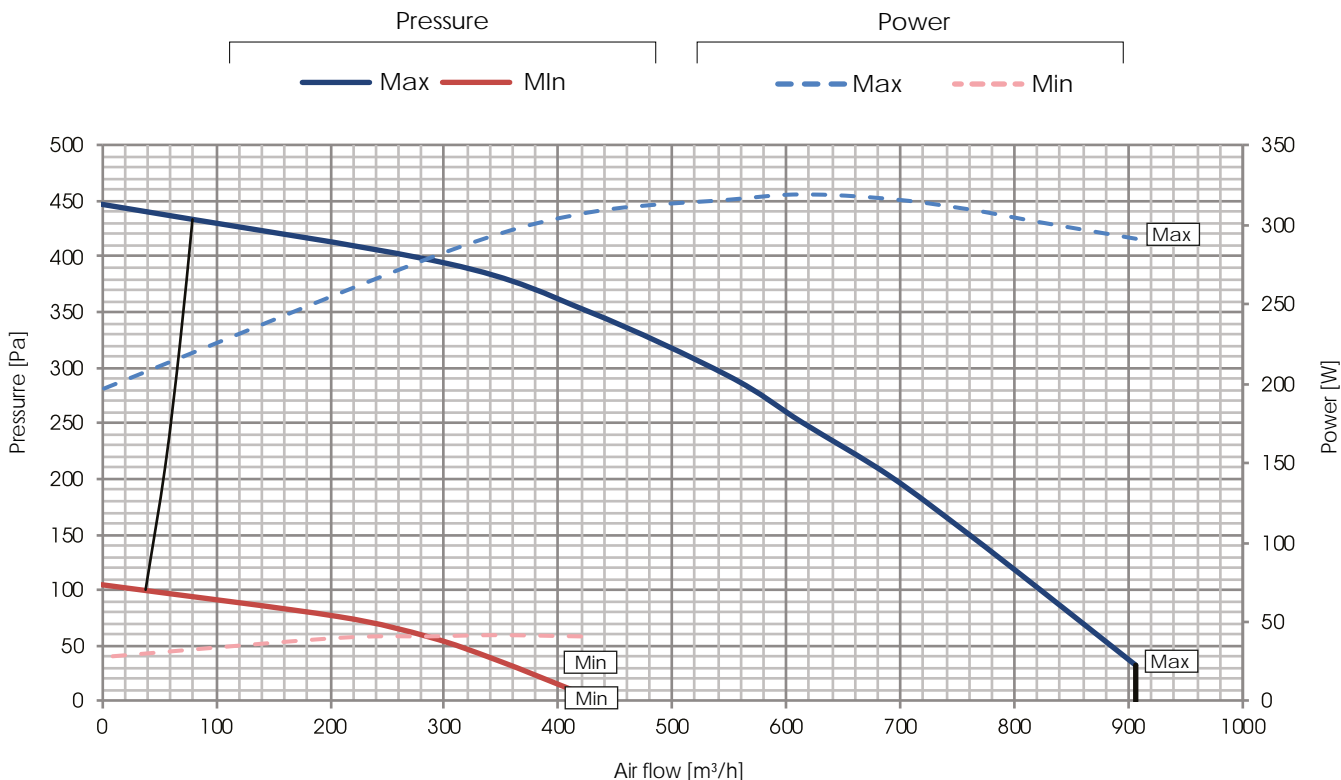



PERFORMANCE (UNI EN 13141-7)

The unit must be ducted properly: UTEK authorizes the use only according to its performance diagram shown into this catalogue
The declared performances are with CLEAN filters, and guaranteed ONLY with the original filters UTEK low pressure drop.

CRHE-TOP 3

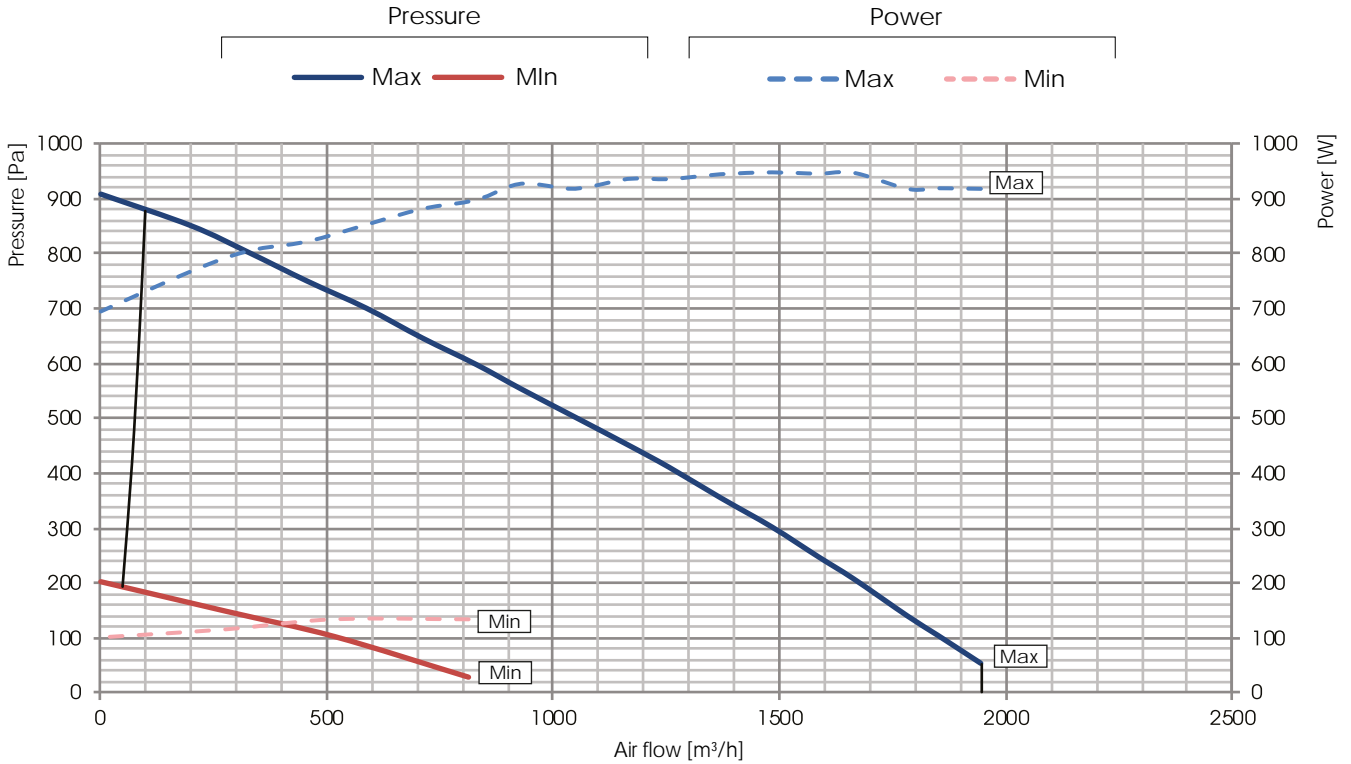

CRHE-TOP 4

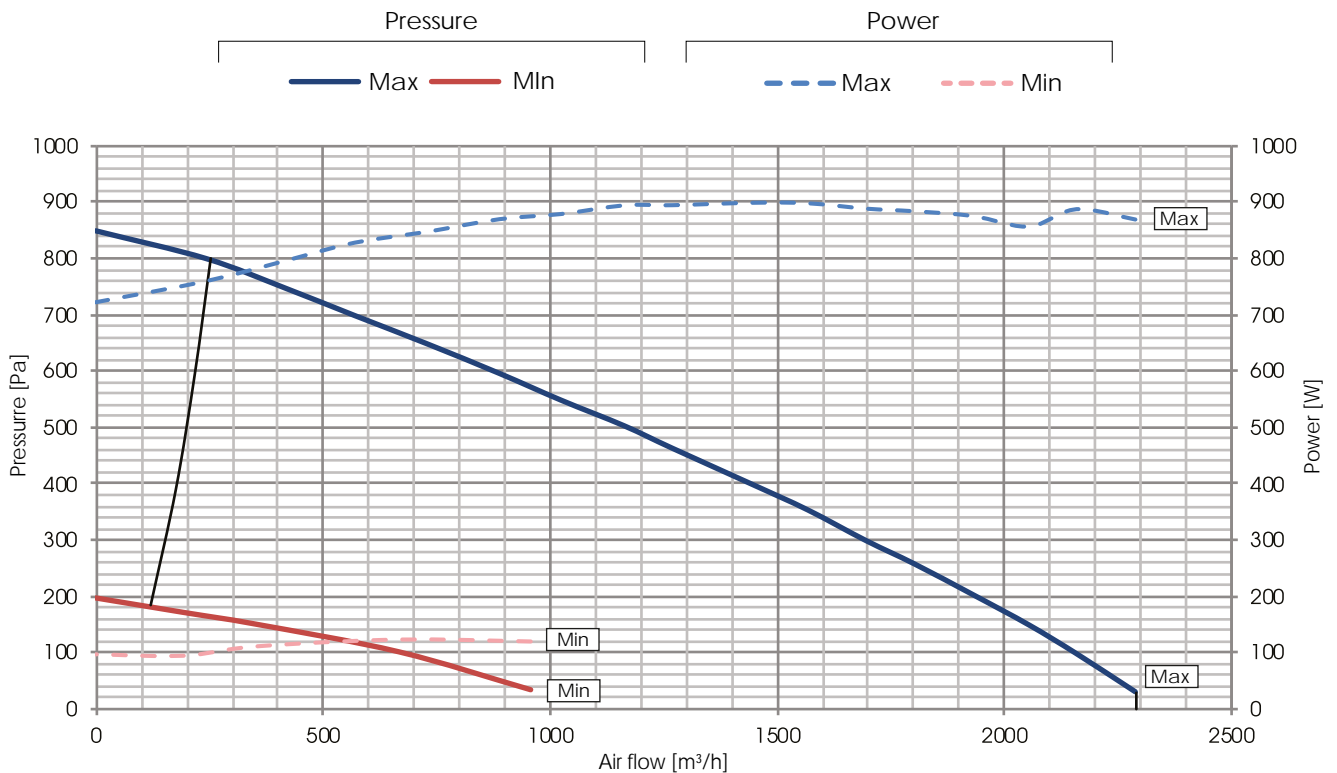



PERFORMANCE (UNI EN 13141-7)

The unit must be ducted properly: UTEK authorizes the use only according to its performance diagram shown into this catalogue
The declared performances are with CLEAN filters, and guaranteed ONLY with the original filters UTEK low pressure drop.

CRHE-TOP 5

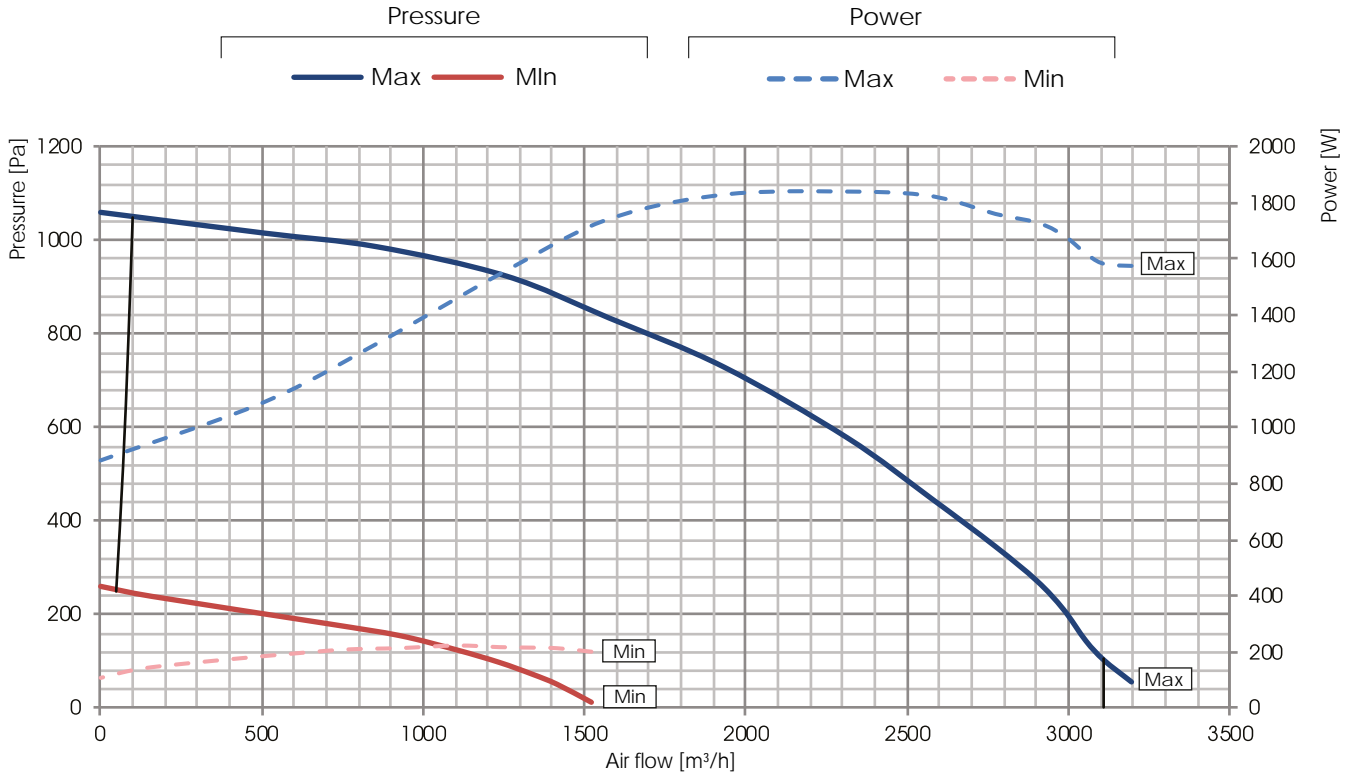

CRHE-TOP 6

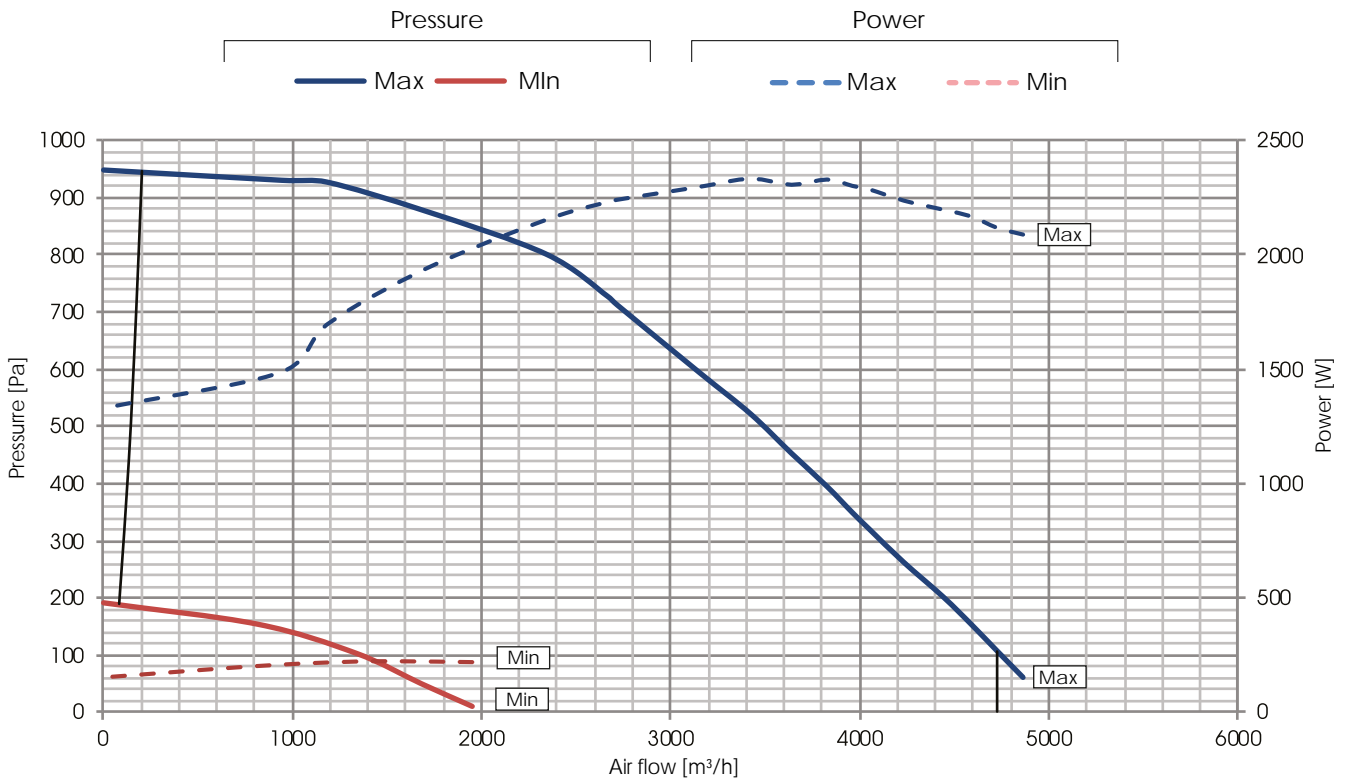



HEAT RECOVERY PERFORMANCE (sensible efficiency)

Values referred to the following conditions (UNI EN 308:1998): Tbs external air 5°C; U.R. external 72%; Tbs environment 25°C; U.R. environment 38%

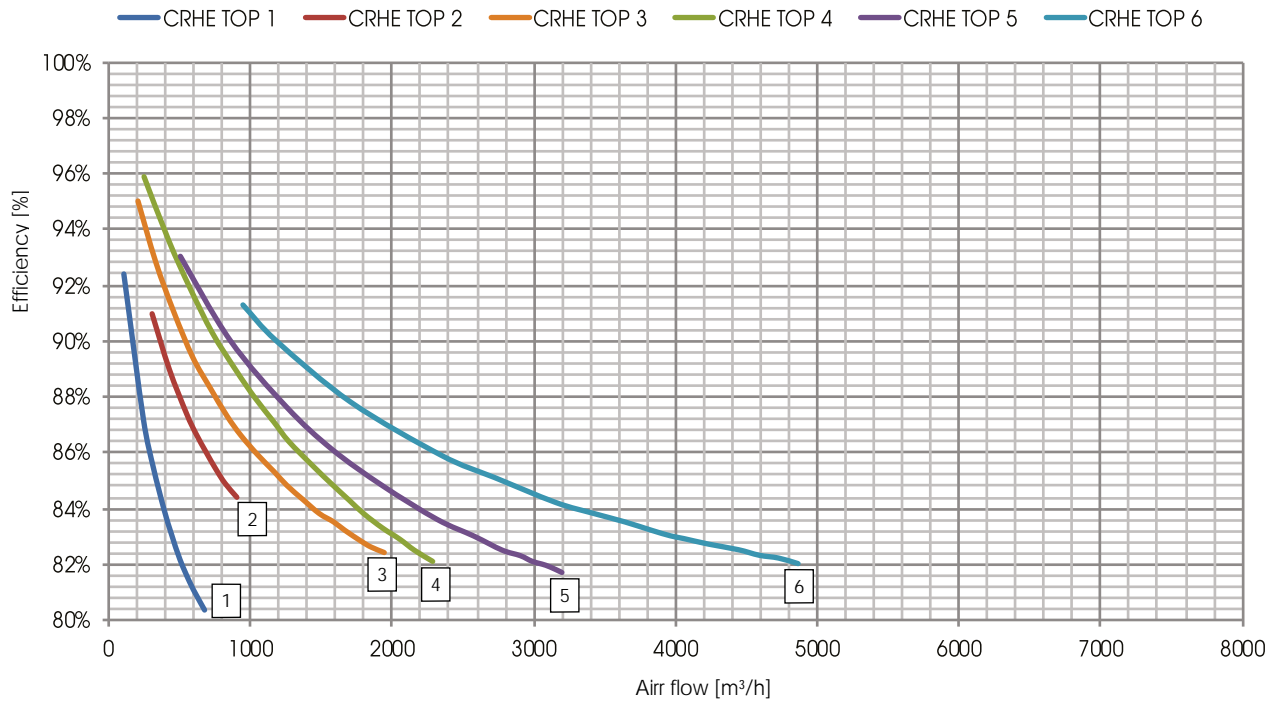

ECODESIGN

MOD.	$\eta_{t,nvru}$ [%]	Q_{nom} [m³/s]	$\Delta p_{s,ext}$ [Pa]	P [kW]	SFP _{int} [W/(m³/s)]	SFP _{int_lim 2016} [W/(m³/s)]	SFP _{int_lim 2018} [W/(m³/s)]	FRONTAL SPEED [m/s]	$\Delta p_{s,int}$ [Pa]	η_{fan} [%]	* LEAKAGE internal [%]	* LEAKAGE external [%]
CRHE TOP 1	80,9	0,17	100	0,26	1017	1590	1310	1,80	749	58,8	10,1	7,8
CRHE TOP 2	84,9	0,23	100	0,31	915	1702	1422	1,66	681	60,5	8,7	5,1
CRHE TOP 3	82,6	0,52	100	0,88	1093	1590	1310	1,85	608	53,9	7,6	4,8
CRHE TOP 4	82,5	0,60	100	0,87	960	1576	1296	1,99	447	44,7	7,2	4,7
CRHE TOP 5	81,9	0,86	110	1,56	1226	1518	1238	2,16	700	53,9	4,4	3,6
CRHE TOP 6	82,2	1,31	110	2,12	1169	1459	1179	2,33	718	63,4	4,6	4,0

* Compared to qnom

VALUES ACCORDING TO UNI EN 1886: 2008

MOD.	CASING STRENGTH	CASING LEAKAGE	FILTERS CLASS	THERMAL TRANSMITTANCE	THERMAL BRIDGE
CRHE TOP 1	D1 (M)	L3 (M)	ePM1 70% (F7) (M)	T4 (M)	TB4 (M)
CRHE TOP 2	D1 (M)	L3 (M)	ePM1 70% (F7) (M)	T4 (M)	TB4 (M)
CRHE TOP 3	D1 (M)	L3 (M)	ePM1 70% (F7) (M)	T4 (M)	TB4 (M)
CRHE TOP 4	D1 (M)	L3 (M)	ePM1 70% (F7) (M)	T4 (M)	TB4 (M)
CRHE TOP 5	D1 (M)	L3 (M)	ePM1 70% (F7) (M)	T4 (M)	TB4 (M)
CRHE TOP 6	D1 (M)	L3 (M)	ePM1 70% (F7) (M)	T4 (M)	TB4 (M)

TEST LEAKAGE (UNI EN 13141-7)

LEAKAGE	TEST CONDITIONS	LEAKAGE CLASSIFICATION					
		CRHE-TOP 1	CRHE-TOP 2	CRHE-TOP 3	CRHE-TOP 4	CRHE-TOP 5	CRHE-TOP 6
ESTERNO	Positive pressure 400 Pa	A3	A2	A2	A2	A2	A2
ESTERNO	Negative pressure 400 Pa	A3	A2	A2	A2	A2	A3
INTERNO	Pressure difference 250 Pa	A3	A3	A3	A3	A2	A2



NOISE LEVEL

L_w Sound power level taken in accordance to UNI EN ISO 3747 - CLASS 3

CRHE-TOP 1	NOISE FROM THE CASE (dB)							
	125 Hz	250 Hz	500 Hz	1000 Hz	2000 Hz	4000 Hz	8000 Hz	L _w dB(A)
	57,5	65,4	58,7	52,4	47,2	40,6	40,6	60,5
CRHE-TOP 1	NOISE IN THE DUCTS (dB)							
	125 Hz	250 Hz	500 Hz	1000 Hz	2000 Hz	4000 Hz	8000 Hz	L _w dB(A)
	67,2	78,9	64,3	59,9	56,8	55,4	57,4	71,7
CRHE-TOP 2	NOISE FROM THE CASE (dB)							
	125 Hz	250 Hz	500 Hz	1000 Hz	2000 Hz	4000 Hz	8000 Hz	L _w dB(A)
	61,9	67,0	57,0	51,5	45,9	39,7	34,0	60,7
CRHE-TOP 2	NOISE IN THE DUCTS (dB)							
	125 Hz	250 Hz	500 Hz	1000 Hz	2000 Hz	4000 Hz	8000 Hz	L _w dB(A)
	67,8	84,1	60,0	61,6	60,8	60,0	56,3	76,1
CRHE-TOP 3	NOISE FROM THE CASE (dB)							
	125 Hz	250 Hz	500 Hz	1000 Hz	2000 Hz	4000 Hz	8000 Hz	L _w dB(A)
	61,5	71,5	60,3	52,9	49,8	41,5	43,2	64,5
CRHE-TOP 3	NOISE IN THE DUCTS (dB)							
	125 Hz	250 Hz	500 Hz	1000 Hz	2000 Hz	4000 Hz	8000 Hz	L _w dB(A)
	72,8	77,9	69,4	69,9	66,7	63,4	72,4	76,6
CRHE-TOP 4	NOISE FROM THE CASE (dB)							
	125 Hz	250 Hz	500 Hz	1000 Hz	2000 Hz	4000 Hz	8000 Hz	L _w dB(A)
	60,7	70,3	59,8	57,5	50,0	43,8	49,8	64,4
CRHE-TOP 4	NOISE IN THE DUCTS (dB)							
	125 Hz	250 Hz	500 Hz	1000 Hz	2000 Hz	4000 Hz	8000 Hz	L _w dB(A)
	71,6	80,6	70,4	70,5	68,0	64,1	68,8	77,0
CRHE-TOP 5	NOISE FROM THE CASE (dB)							
	125 Hz	250 Hz	500 Hz	1000 Hz	2000 Hz	4000 Hz	8000 Hz	L _w dB(A)
	67,3	72,2	66,6	59,8	57,2	50,0	54,3	68,2
CRHE-TOP 5	NOISE IN THE DUCTS (dB)							
	125 Hz	250 Hz	500 Hz	1000 Hz	2000 Hz	4000 Hz	8000 Hz	L _w dB(A)
	77,6	82,3	81,6	78,0	73,6	70,6	80,2	84,5
CRHE-TOP 6	NOISE FROM THE CASE (dB)							
	125 Hz	250 Hz	500 Hz	1000 Hz	2000 Hz	4000 Hz	8000 Hz	L _w dB(A)
	68,2	75,7	60,8	52,3	49,6	45,4	48,1	67,9
CRHE-TOP 6	NOISE IN THE DUCTS (dB)							
	125 Hz	250 Hz	500 Hz	1000 Hz	2000 Hz	4000 Hz	8000 Hz	L _w dB(A)
	82,0	90,0	74,0	68,8	64,3	66,9	71,2	82,6

ELECTRICAL DATA

MATCHING	FAN				UNIT CRHE-TOP		
	Power [W]	Supply	Current max.[A]	Insulation class	Supply	Current max.[A]	Insulation class
CRHE TOP 1	2 x 161	230V 50 Hz 1F	2 x 1,0	IP54 CLASS B	230V 50 Hz 1F	2,5	IP 20
CRHE TOP 2	2 x 193	230V 50 Hz 1F	2 x 1,2	IP54 CLASS B	230V 50 Hz 1F	2,9	IP 20
CRHE TOP 3	2 x 448	230V 50 Hz 1F	2 x 2,8	IP54 CLASS B	230V 50 Hz 1F	6,2	IP 20
CRHE TOP 4	2 x 448	230V 50 Hz 1F	2 x 2,8	IP54 CLASS B	230V 50 Hz 1F	6,2	IP 20
CRHE TOP 5	2 x 1000	400V 50 Hz 3F	2 x 1,6	IP55 CLASS F	400V 50 Hz 3F	3,3	IP 20
CRHE TOP 6	2 x 1100	400V 50 Hz 3F	2 x 1,7	IP54 CLASS B	400V 50 Hz 3F	3,8	IP 20



DIMENSIONS (mm) WEIGHT (kg)

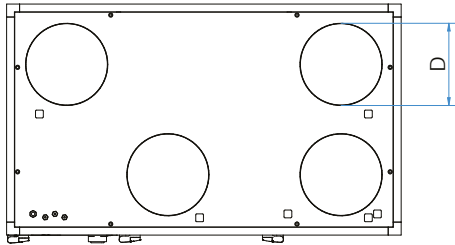
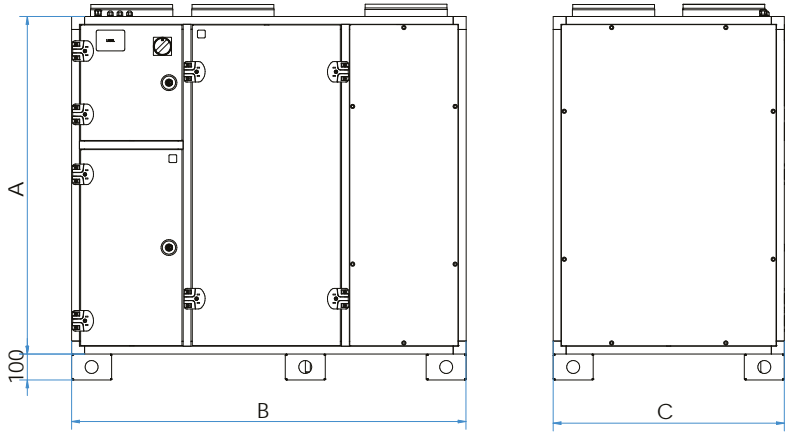

MODEL	Dimensions [mm]				Weight [kg]
	A	B	C	D	
CRHE TOP 1	1100	1100	610	200	125
CRHE TOP 2	1200	1300	700	250	175
CRHE TOP 3	1300	1520	890	315	211
CRHE TOP 4	1300	1700	1000	355	252
CRHE TOP 5	1500	1900	1060	400	300
CRHE TOP 6	1600	2200	1400	500	419

FLOOR INSTALLATION

Minimum required space for maintenance (mm)

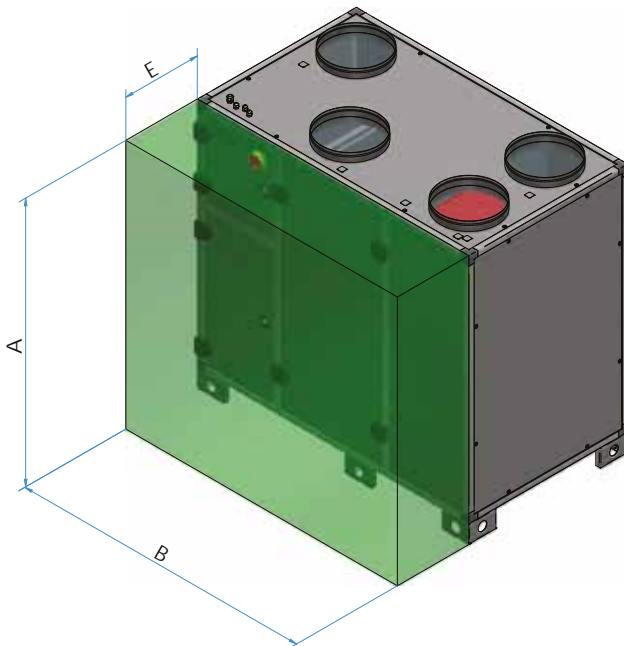

MODEL	Dimensions [mm]		
	A	B	E
CRHE TOP 1	1200	1100	500
CRHE TOP 2	1300	1300	500
CRHE TOP 3	1400	1520	750
CRHE TOP 4	1400	1700	500
CRHE TOP 5	1600	1900	500
CRHE TOP 6	1700	2200	650

A	Manufacturer's name	C.L.A. S.r.l.	CRHE-TOP 1 EVO-PH SV	CRHE-TOP 2 EVO-PH SV	CRHE-TOP 3 EVO-PH SV	CRHE-TOP 4 EVO-PH SV
B	Manufacturer's model identifier					
C	Declared typology		UVNR / UVB	UVNR / UVB	UVNR / UVB	UVNR / UVB
D	Type of drive installed		Variable speed drive	Variable speed drive	Variable speed drive	Variable speed drive
E			other	other	other	other
F	Thermal efficiency of heat recovery [%]		80,9	84,9	82,6	82,5
G	Nominal NRVU flow rate [m³/s]		0,17	0,23	0,52	0,60
H	Effective electric power input [kW]		0,26	0,31	0,88	0,87
I	SFPint [W/[m³/s]		1017	915	1093	960
J	Face velocity at design flow rate [m/s]		1,8	1,6	1,8	1,9
K	Nominal external pressure [Pa]		100	100	100	100
L	Internal pressure drop of ventilation components [Pa]		749	681	608	447
M	Optional: internal pressure drop of non-ventilation components		-	-	-	-
N	Static efficiency of fans used in accordance with Regulation (EU) No 327/2011 [%]		58,8	60,5	53,9	44,7
	Declared maximum external leakage rate of the casing of ventilation units [%]		7,8	5,1	4,8	4,7
O	Declared maximum internal leakage rate of bidirectional ventilation units or carry over (for regenerative heat exchangers only) [%]		10,1	8,7	7,6	7,2
P	Energy performance, preferably energy classification, of the filters (declared information about the calculated annual energy consumption)		ePM1 55% (F7) ePM10 50% (M5)	ePM1 55% (F7) ePM10 50% (M5)	ePM1 55% (F7) ePM10 50% (M5)	ePM1 55% (F7) ePM10 50% (M5)
Q	Position and description of visual filter warning for RVUs intended for use with filters, including text pointing out the importance of regular filter changes for performance and energy efficiency of the unit		Filter warning is signaled on the display of the control system: the flashing writing "DirtyFilters" will appear. "To preserve the energy efficiency of the NRVU, it's recommended to replace the filters when signaled." Positioned near the filters inspection.			
R	Casing sound power level (LWA) [dB]		60,5	60,7	64,5	64,4
S	Internet address for pre-/dis-assembly instructions		www.utek-air.it			

A	Manufacturer's name	C.L.A. S.r.l.	
B	Manufacturer's model identifier	CRHE-TOP 5 EVO-PH SV	CRHE-TOP 6 EVO-PH SV
C	Declared typology	UVNR / UVB	UVNR / UVB
D	Type of drive installed	Variable speed drive	Variable speed drive
E		other	other
F	Thermal efficiency of heat recovery [%]	81,9	82,2
G	Nominal NRVU flow rate [m³/s]	0,86	1,31
H	Effective electric power input [kW]	1,56	2,12
I		1226	1169
J	Face velocity at design flow rate [m/s]	2,16	2,33
K	Nominal external pressure [Pa]	100	100
L	Internal pressure drop of ventilation components [Pa]	700	718
M	Optional: internal pressure drop of non-ventilation components		-
N	Static efficiency of fans used in accordance with Regulation (EU) No 327/2011 [%]	53,9	63,4
	Declared maximum external leakage rate of the casing of ventilation units [%]	3,6	4,0
O	Declared maximum internal leakage rate of bidirectional ventilation units or carry over (for regenerative heat exchangers only) [%]	4,4	4,6
P	Energy performance, preferably energy classification, of the filters (declared information about the calculated annual energy consumption)	ePM1 55% (F7) ePM10 50% (M5)	ePM1 55% (F7) ePM10 50% (M5)
Q	Position and description of visual filter warning for RVUs intended for use with filters, including text pointing out the importance of regular filter changes for performance and energy efficiency of the unit	Filter warning is signaled on the display of the control system: the flashing writing "DirtyFilters" will appear. "To preserve the energy efficiency of the NRVU, it's recommended to replace the filters when signaled." Positioned near the filters inspection.	
R	Casing sound power level (LWA) [dB]	68,2	67,9
S	Internet address for pre-/dis-assembly instructions	www.utek-air.it	

CLA & UTEK reserves the right to at any time the necessary changes to improve products without prior notice .

Dear Customer

Thanks for your attention to the product UTEK , designed and manufactured to ensure the real values to the User : Quality, Safety and Savings on working.



Made in Italy

**AZIENDA CON SISTEMA
DI GESTIONE QUALITÀ
CERTIFICATO DA DNV GL
ISO 9001**

**AZIENDA CON
SISTEMA DI GESTIONE
AMBIENTALE CERTIFICATO
DA DNV
ISO 14001**



the Dealer

CRHE-TOP_2022_0_IT
Validity from 15/12/2022



VENTILATION UNIT WITH HEAT RECOVERY FOR COMMERCIAL AND INDUSTRIAL BUILDINGS